

Finishing (Painting or Staining) Instructions:

NOTE: Differences in grain and color variations are indicative of natural wood. These are not considered product defects. Some variations in stain penetration may occur between materials from which the door is constructed (i.e. plywood panel vs. wood frame).

Preparation Work

Important information: Wood products can absorb moisture during shipping and storage. Do not leave or store unfinished doors outside. It is important that all sections be free of moisture prior to finishing the sections. Wood doors should not be finished under very humid conditions (storing the door in such an environment will void the warranty on the door). In order to ensure that all door surfaces are properly finished, it is **required** that the door sections be finished **prior to installation**. **Failure to properly and completely finish all door section surfaces, including the sides, back, bottom, face, and joints, will void the warranty on the door.**

Painting Your Door

Step 1: Fill any gaps or voids within wood surfaces with a caulking compound that can be painted. (Do not use silicone as it cannot be painted.)

NOTE: For optimum long lasting performance the spaces between the rails or stiles and the door panel should be caulked. For plywood and hardboard panel doors, all (4) sides of each panel should be caulked. (Fig. F-1) For hemlock, cedar, or redwood panel doors with wood grain running horizontally, the bottom, left, and right sides of the panels should be caulked (Fig. F-2). For hemlock, cedar, or redwood panel doors with wood grain running vertically, the top and bottom of the panels should be caulked (Fig. F-3).

Step 2: Clean all door surfaces with a stiff bristle brush to remove surface dirt, dust, and loose fibers.

Step 3: Before finish painting, the door section must be primed on all sides. Wood doors can be ordered either primed or unprimed (primed doors can be identified by the light-green finish). If your door is pre-primed, proceed to step 4 below. Prime all section surfaces using a quality oil or latex based exterior primer, taking care to observe the primer manufacturer's application instructions, including recommendations on temperature and drying time. If you are painting a redwood or cedar door, the primer must contain a tannin blocker. **Using a primer on redwood and cedar doors that does not contain a tannin blocker could result in discoloration of the door after painting.**

Step 4: Finish paint all door section surfaces using a quality oil or latex based exterior paint. **The finish coat base should be the same as the primer coat base** (i.e. a latex based finish paint is recommended for use with a latex based primer, and an oil based finish paint is recommended for use with an oil based primer). **If your door is factory primed, a latex based finish paint must be used.** Carefully follow all manufacturers' application instructions, including recommendations on temperature and drying time. A second top coat is recommended for optimum protection.

Staining Your Door

Note: The following door models cannot be stained: 10, 19 (Hardboard Panels), any model ending in "G" or "P". If your door is one of these models, refer to the painting instructions above.

Step 1: Select a quality exterior oil-based penetrating stain (transparent, semi-transparent, or solid) that is mildew resistant, UV resistant, and water repellent. Selection of a stain or finish that does not have these properties will void the warranty on the door. Do not use film-forming finishes, such as varnishes and urethanes, which do not penetrate the wood.

Step 2: Clean all door surfaces with a stiff bristle brush to remove surface dirt, dust, and loose fibers.

Step 3: Apply stain to all door section surfaces per stain manufacturer's instructions, including recommendations on temperature and drying time.

Step 4: Fill any gaps or voids within wood surfaces with a clear silicone caulk.

NOTE: For optimum long lasting performance the spaces between the rails or stiles and the door panel be caulked. For plywood and hardboard panel doors, all (4) sides of each panel should be caulked. (Fig. F-1) For hemlock, cedar, or redwood panel doors with wood grain running horizontally, the bottom, left, and right sides of the panels should be caulked (Fig. F-2). For hemlock, cedar, or redwood panel doors with wood grain running vertically, the top and bottom of the panels should be caulked (Fig. F-3).

- To avoid an uneven caulk line that could affect the appearance of the wood surrounding the panel joints, apply masking tape to both the panel and the stile or rail along the entire joint prior to caulking, leaving a gap of 1/8". Caulk along the joint, pressing the caulk into the joint and smoothing with finger. After entire bead is applied, remove tape. (Fig. F-4)

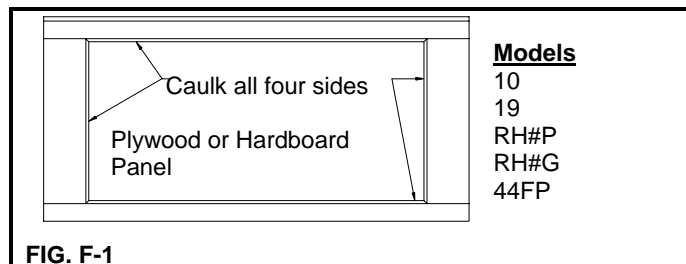

FIG. F-1

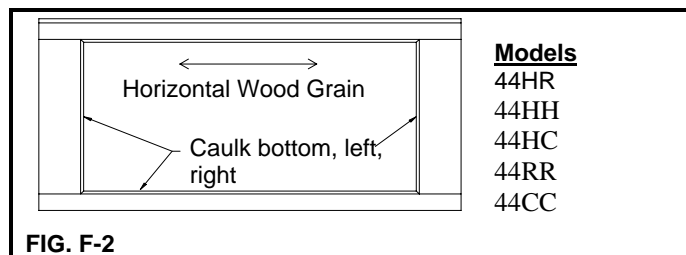

FIG. F-2

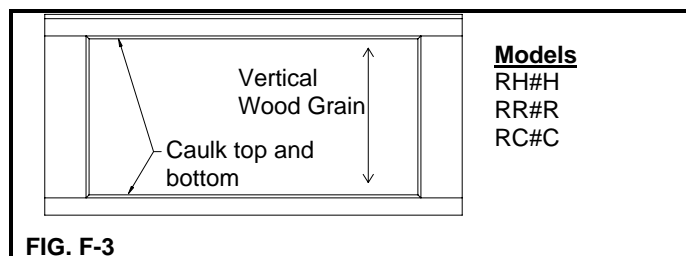

FIG. F-3

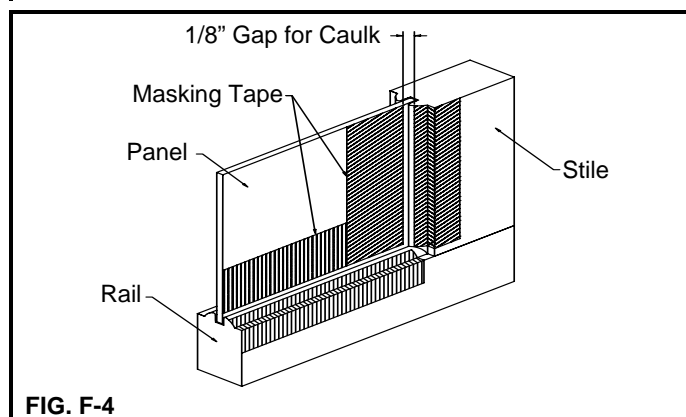

FIG. F-4

Maintaining Your Painted or Stained Door

The two major contributing factors to the breakdown of the door's finish (ultimately resulting in rotting and warpage) are sun and moisture. Annually examine your door for any signs of paint finish cracking or peeling or for any cracks in the wood door section. If the door is painted, the manufacturer recommends that it be repainted every 1-2 years to protect or seal the door against the elements. Failure to do so will result in voiding of the warranty. If the door is stained, reapply stain as needed per the stain manufacturer's recommendations. In general, the clearer the stain, the more it will need to be reapplied.

Remember, the quality, properties, and composition of exterior paints and stains vary greatly among manufacturers and among different products. Fill in the form below and keep this manual to ensure compliance with the door manufacturer's recommendations and for future maintenance of your door finish.

Minor cracks in the wood should be repaired by filling in the area with an exterior grade caulk compound and then refinished following the previous instructions. Failure to repair cracks could potentially lead to more extensive section damage in the future. Gouges in the wood surface can be repaired with a wood filler. If extensive damage occurs to the door, the door manufacturer recommends that the door section be replaced. Failure to do so could result in damage or injury to property or individuals in the garage.

Annual Maintenance

- 1) Lubricate all moving parts of the door with light household oil, including:
 - a) Lift cables at the bottom bracket button
 - b) Bearing of the sheaves
 - c) Lock hardware where surfaces turn or slide
 - d) Full length of torsion spring to reduce friction between coils
 - e) Lubricate steel rollers. DO NOT lubricate nylon rollers.
- 2) Check for loose or bent hinges.
 - a) Tighten loose hinges.
 - b) Straighten or replace bent hinges.

Caution: To replace bent hinge(s) or broken roller(s):

Door must be locked and in the down position.

No more than 1 hinge is to be removed from the door at any given time.

Under no circumstances should you loosen or remove the bottom bracket.

- 3) Check roller for broken wheels, bent shafts, or worn out bearings. Check the door and track supports for loose or missing bolts, screws, etc. Be careful not to over tighten.
- 4) Check the extension cables. Are they running properly in the sheaves? Check for wear of the cable at the bottom bracket button.
- 5) Check for bent track. If bent, call an authorized professional dealer.
- 6) Extension spring hardware, including springs, cables, sheaves, sheave forks, bottom brackets, and containment cables, should be adjusted or repaired only when the spring tension is released (the door must be open). These repairs should be made by a qualified door technician or a mechanically experienced person with proper tools and instructions.
- 7) If your door has torsion springs, the spring assembly and wood anchor pad should only be adjusted or repaired by a professional door technician.

Replacement Parts

Replacement parts are available from an authorized professional dealer or a building supply retailer. When ordering repair parts, always provide the following: part name, model number, and door width and door height (W x H). For the location of the authorized professional dealer or a building supply retailer nearest you, please write or call:

Clopay Building Products
Consumer Services Dept.
101 Miller Rd.
Russia, OH 45363 USA

Call Toll Free: 1-800-225-6729
Hours of Operation (EST):
Monday – Friday, 8:30 AM - 7 PM
Saturday 8:30 AM - 5 PM.

PAINTED	STAINED
Primer Factory Primed? <input type="checkbox"/> Consumer Primed? <input type="checkbox"/> Brand/Product Name: _____ Finish Paint Brand/Product Name: _____ Color: _____	Stain Brand/Product Name: _____ Color: _____ Penetrating? <input type="checkbox"/> UV Resistant? <input type="checkbox"/> Mildew Resistant? <input type="checkbox"/> Water Repellant? <input type="checkbox"/> Reapply every _____ years.
MAINTENANCE HISTORY	
Purchase Date _____ Install / Finish Date _____	
Date	Repair, Maintenance, or Refinish