

## STEP 10 - Reinforcing the Top Section for Opener

To avoid damage to your door, you must reinforce the top section of the door in order to provide a mounting point for the opener to be attached. You will need one (1), two (2), or three (3) pieces of 1-1/4" x 1-1/4" minimum punched angle at least 13 gauge or 3/32" thick from your local hardware or building supply store. Figures 10-B to 10-E show how punched angle is to be affixed to door.

### Horizontal Angle Attachment

Attach the horizontal punched angle (the longer piece) to the top section as shown in Figure 10-A. Angle iron may need to be trimmed depending on door section height and distance between center stiles. Some doors with struts may not need a horizontal angle; see Figures 10-B to 10-E to identify the attachment method for your specific door.

**Do NOT install the bracket supplied with the opener. Failure to reinforce the door, as illustrated, will void your warranty.**

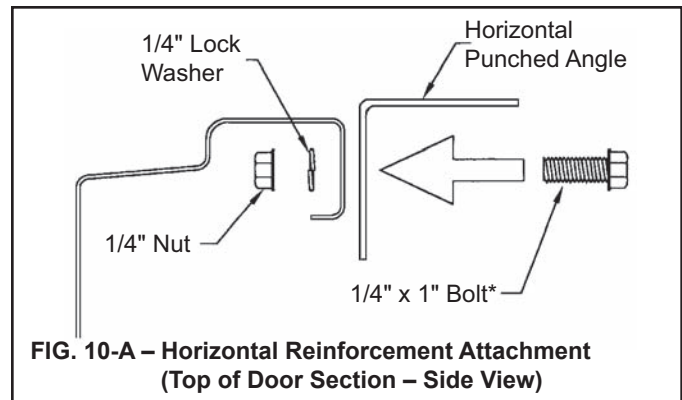
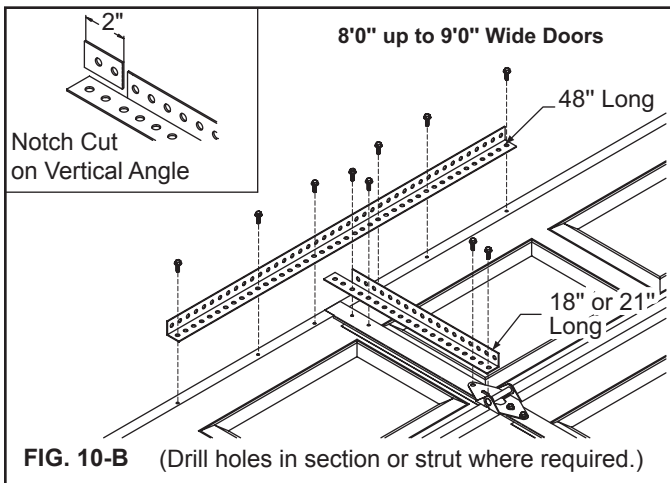

FIG. 10-A – Horizontal Reinforcement Attachment (Top of Door Section – Side View)

\*Fully-insulated doors use 1/4" x 3/4" self tapping screw.

**NOTE:** An opener bracket kit specifically designed for opener attachment may be purchased as an option (silver galvanized or white powder coated). Instructions are provided with the kit.

**NOTE:** Operator may be attached up to 2 feet off center. (Doors with Torsion Springs Only)



Required materials:  
 (1) 18" or 21" and (1) 48" length of angle iron,  
 (6) 1/4"x1" bolts, (6) 1/4" lock washers, (6) 1/4" nuts, and  
 (4) #14 x 5/8" sheet metal screws.

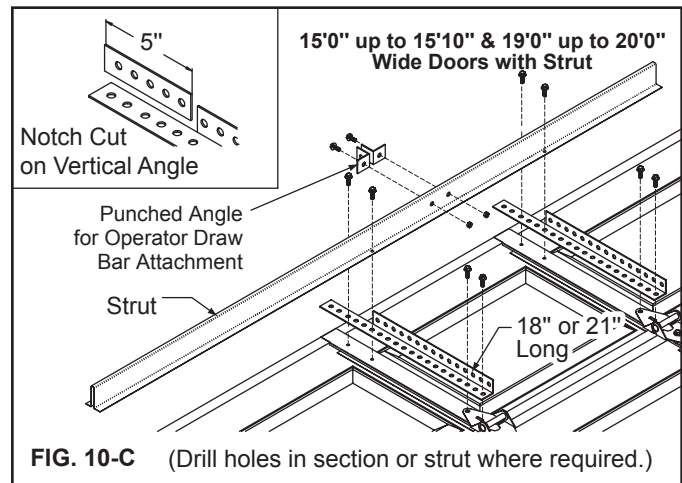

Required materials:  
 (2) 18" or 21" lengths of angle iron,  
 (2) 1/4"x1" bolts, (2) 1/4" lock washers, (2) 1/4" nuts,  
 (4) #14 x 5/8" sheet metal screws, and  
 (4) 1/4" x 3/4" self tapping screws.

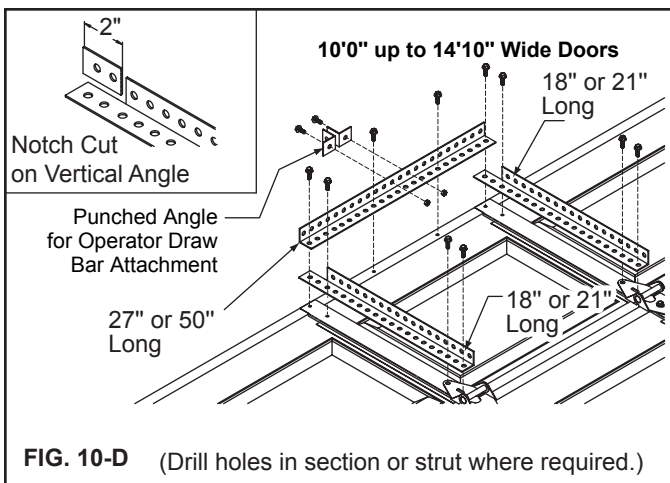

Required materials:  
 (2) 18" or 21" and (1) 27" or 50" length of angle iron  
 (4) 1/4"x1" bolts, (4) 1/4" lock washers, (4) 1/4" nuts, and  
 (8) #14 x 5/8" sheet metal screws.

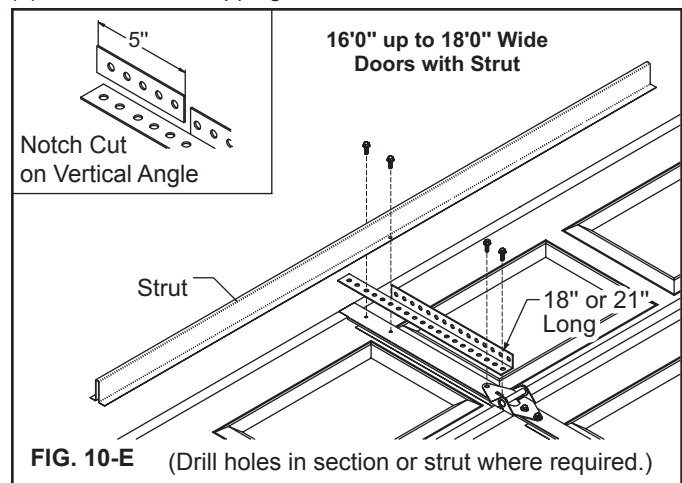

Required Materials:  
 (1) 18" or 21" length of angle iron,  
 (2) #14 x 5/8" sheet metal screws, and  
 (2) 1/4" x 3/4" self tapping screws.

## STEP 15 – Attaching an Automatic Opener

**IMPORTANT:** To avoid damage to your door, you must reinforce the top section of the door in order to provide a mounting point for the opener to be attached. Refer to the section of this manual titled Reinforcing the Top Section on page 14 for specific instructions. Failure to reinforce the door as illustrated will void the warranty on your door.



### WARNING

To avoid risk of strangulation or personal injury to children, if your door has a pull rope, you must remove the pull down rope when you install an automatic garage door opener.

**IMPORTANT:** When installing an automatic garage door operator, make sure to follow manufacturer's installation and safety instructions carefully. **Remove the pull down rope and unlock or remove the lock.** If attaching an operator bracket to the wooden anchor pad, make sure the wood anchor pad is free of cracks and splits and is firmly attached to the wall. Always drill pilot holes before attaching lag screws.

The operator arm will usually be attached to the vertical reinforcement member at roughly the same height as the top roller of the door. Attach the opener arm to the reinforcement as shown in Figures 15-B to 15-D. To prevent the top of the door from bending, the opener rail should be mounted no less than 2" and no greater than 5" from the face of the door with the door in the open position (FIG. 15-A). Additionally, when the door is closed, the portion of the operator arm attached to the door should be at angle of approximately 60 degrees from the vertical (FIG. 15-B).

### Opener Rail Mounting Distance

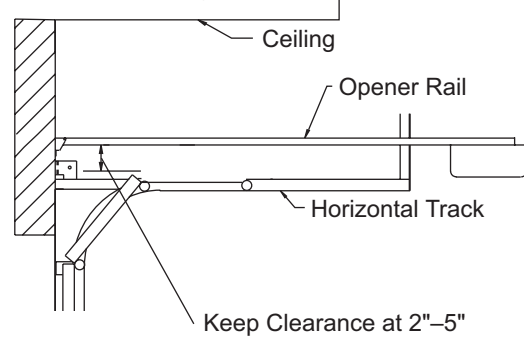

FIG. 15-A

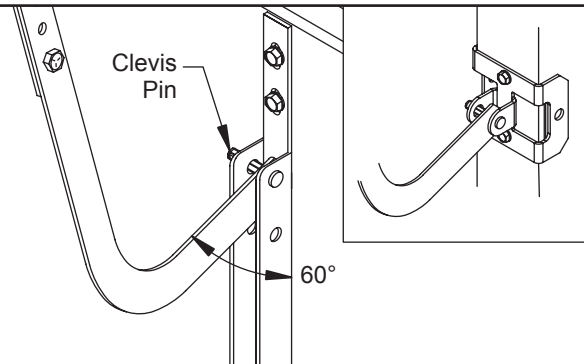
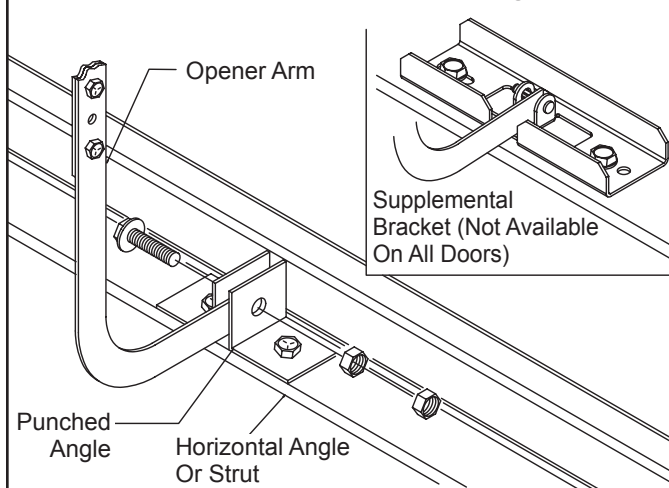

FIG. 15-B (Doors with supplied Reinforcement Bracket and Stile in Center of Door)

### Opener Arm Attachment To Horizontal Angle Or Strut



#### Front View (Assembled)

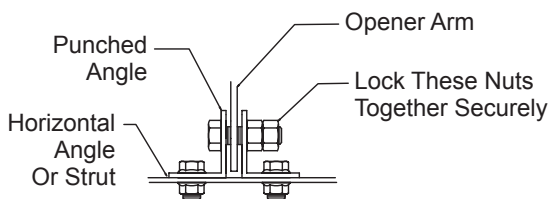
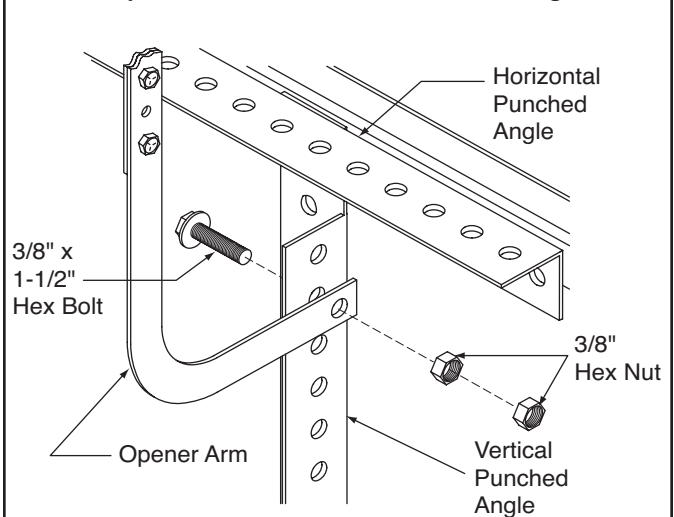

FIG. 15-C (Doors with odd number of Panels)

### Opener Arm Attachment To Vertical Angle



#### Top View (assembled)

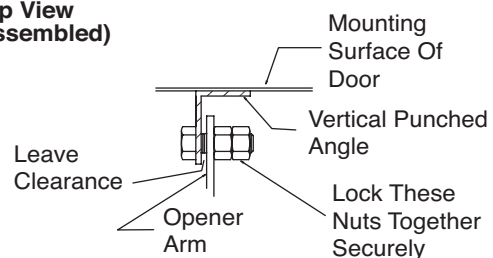

FIG. 15-D (Doors with Angle Iron Reinforcement Bracket and Stile in Center of Door)