



Fire Shutter
Installation Instructions

Model CERC10

Section	Page
Safety Check List	2.1
Freight Receiving	3.1
Pre-installation	4.1
Guides – Face-of-Wall	5.1
Guides – Between-Jambs	5.4
Barrel and Brackets - Preparation	6.1
Barrel and Brackets – Ring Attachment	6.2
Barrel and Brackets – Bracket Preparation	6.3
Barrel and Brackets – Hoisting and Installing Barrel Assembly	6.4
Motor Operator Installation	7.1
Curtain Installation	8.1
Spring Release Setup – Applying Spring Turns	9.1
Spring Release Setup – Fusible Link Assembly - Conventional Fire Shutter	9.2
Spring Release Setup – Fusible Link Assembly - M100 Fire Shutter	9.3
Spring Release Setup – Fusible Link Assembly – Through wall conduit	9.4
Hood Support Installation	10.1
Hood, Fascia, and Covers – Lintel brush	10.2
Hood, Fascia, and Covers – Hood and Fascia	10.3
Hood, Fascia, and Covers – Covers	10.4
Drop Testing	11.1
Torque Specifications	12.1
Maintenance Schedule	13.1
Appendix A – Sealant application for NFPA 105 / UL 1784 compliance	14.1

Rolling doors are large, movable objects. They move with the help of electric motors or manual operators (chain, crank, push up, etc), and most have springs under high tension. These items and their components can cause injury. In order to avoid injury to yourself and others, please follow the instructions in this manual.

▪ **Review the potential hazards and preventative measures listed below:**





Potential Hazard		Preventative Measure
	⚠ DANGER Pinned or crushed by closing door.	<ul style="list-style-type: none"> • Keep yourself and others clear of opening while door is in motion. • Do not allow children to play near or operate door. • Do not operate if door becomes jammed or broken.
	⚠ WARNING Struck by adjusting wheel bar while applying spring turns.	<ul style="list-style-type: none"> • Be sure bar is adequate in strength and long enough to allow installer to apply the necessary torque. • Make sure bar is fully seated into the adjusting wheel slot before applying pressure. • Use two bars while applying turns to the adjusting wheel.
	⚠ WARNING Electrical shock.	<ul style="list-style-type: none"> • Make sure electrical operator is properly grounded. • Turn off source power completely prior to servicing the motor. • Make sure wires are clear of any moving or potentially moving parts. • Avoid pinching wires when installing the motor cover.
	⚠ WARNING Pinched by moving components.	<ul style="list-style-type: none"> • Make sure the motor is turned off and unplugged before working with moving parts such as roller chain and sprockets, drop-out mechanisms, adjusting wheels, etc. • Locate the possible pinch-points of the unit (Drive chain, coil area, bottom bar, etc.) Do not operate the door while someone is near these areas.

Table 2.1 - Potential hazards and Preventative Measures

▪ **Check the following during installation and before leaving the job site:**

- a. If the unit has tension springs, be sure the proper amount of tension is applied to the torsion springs, in order to properly counterbalance the weight of the curtain.
- b. Securely fasten the tension adjusting wheel in place with the appropriate hardware provided.
- c. Check that the keys and/or cotter pins have been set in place and fit properly at all sprockets or gears.
- d. Check that the setscrews in each sprocket or gear (one over the key and one offset from the key) have been tightened properly.
- e. Check all fasteners holding the unit to the building structures.
- f. Check all fasteners used to assemble the components of the unit together.
- g. Instruct owner or representative in the proper method of operating the door.

- **Upon delivery, check condition of components for damage.**
- **If damage occurred in transit, the installation should not proceed without authorization.**

NOTICE

If the installation proceeds, neither the carrier nor the manufacturer will assume responsibility for replacing the damaged material.

- **If the installation is stopped due to damage, do the following:**
 1. Take pictures of the damage.
 2. Do not move material from point of delivery to other premises once the damaged components are discovered.
 3. Do not unpack, if the damage is visible prior to removing packaging, until an inspection is made.
 4. If the damage is found while removing contents from packaging, the packaging material must be saved until inspection is made.
 5. Container and packaging should be retained by consignee until inspection is made.
 6. Have components inspected by carrier's representative within 15 days from date of delivery.
 7. Consignee must obtain a copy of the Inspection Report.
- **Returning damaged components:**
 1. Obtain permission from carrier to return.
 2. Route the return shipment via the identical carrier(s) involved in the original shipment.
 3. Notify the manufacturer when shipment is returned to manufacture plant.
- **Verify that all components have arrived. Look for the following:**
 1. Job construction drawings featuring different views (elevation, section, plan, etc.)
 2. (2) Guide assemblies; check for guide weathering if included in order
 3. Barrel assembly
 4. Curtain assembly with bottom bar attached
 5. (2) Bracket assemblies
 6. Operator; if not attached to bracket
 7. Operator cover; may not be included in order
 8. Adjusting wheel; if the barrel assembly contains springs
 9. Inertia brake; typically on units with springless barrel assemblies
 10. Hood and hood supports; may not be included in order
 11. Hardware
 12. Misc. items (Reelite, lintel seal, hood baffle, etc.)
 13. Verify material/finish/color of components matches what is listed on the job construction drawings and/or what was ordered.
- **If the delivery is incomplete:**
 1. Make note on delivery receipt.
 2. Note should be verified by driver's signature.
 3. Notify carrier and manufacturer.

- **Read entire instruction manual thoroughly. The manufacturer will not be held responsible for any charges incurred due to improperly installed components.**
 - a. Only trained door systems technicians should perform installation, maintenance, etc.
 - b. Each unit comes with an individual item number. If the job contains multiple units, be sure to locate all the components for each item and separate each.

⚠ WARNING

Do not interchange parts from one door to another.

- c. Find the job construction drawings for the unit being installed and check the dimensions of the opening against those on the drawings. See **Figure 4.1** below.
- d. If the opening dimensions differ from those on the drawings, **do not proceed**, check with distributor/manufacturer to be sure the correct door is being installed.
- e. Check the jambs of the opening for plumb. Check the head/lintel and floor for level. If the unit is to be free standing, for example mounted to tubes, check the floor and ceiling for level and for adequate mounting areas at the top and bottom.

Note: The floor may not be level if a pitched bottom bar is specified.

▪ **Work Area:**

- a. The key to a smooth installation is a clean and well-prepared work environment. Once the components have been inspected and the job construction drawings have been reviewed; lay out the components in the order of installation.
- b. The opening for the door should be cleaned and inspected for rough surfaces and construction debris.
- c. Lastly the mounting hardware supplied with the door should correspond with the surface and construction features of the opening.
- d. The basic assembly sequence is as follows: guides, barrel w/ rings or tapped holes, brackets, motor operator (if applicable), curtain, bellmouth, stoppers, weather stripping, hood, and operator/adjustor/idler covers.

Note: If the unit is required to meet NFPA 105 / UL 1784, see **Appendix A** prior to installation.

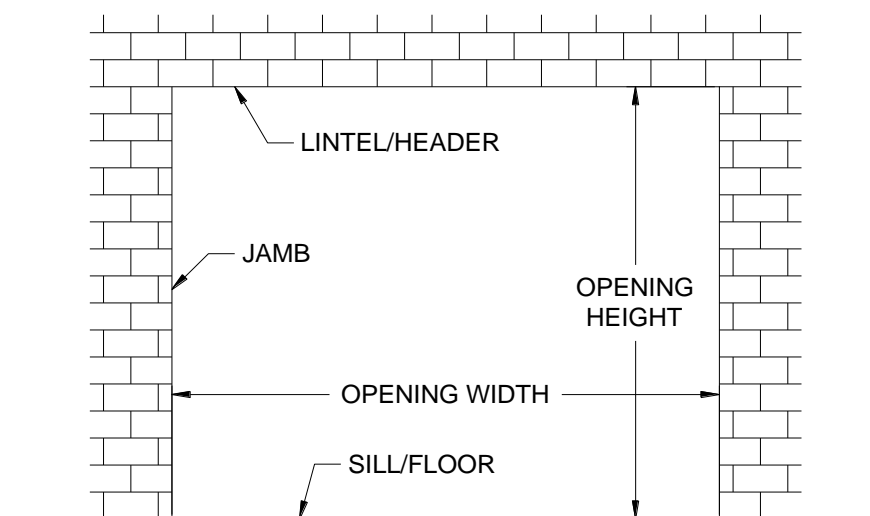

Figure 4.1 - Opening Dimensions and Designations

▪ **Face of Wall Units (Figures 5.1 - 5.4):**

Note: Determine the specified guide configuration for the door from the job construction drawings. Compare to the diagrams below.¹

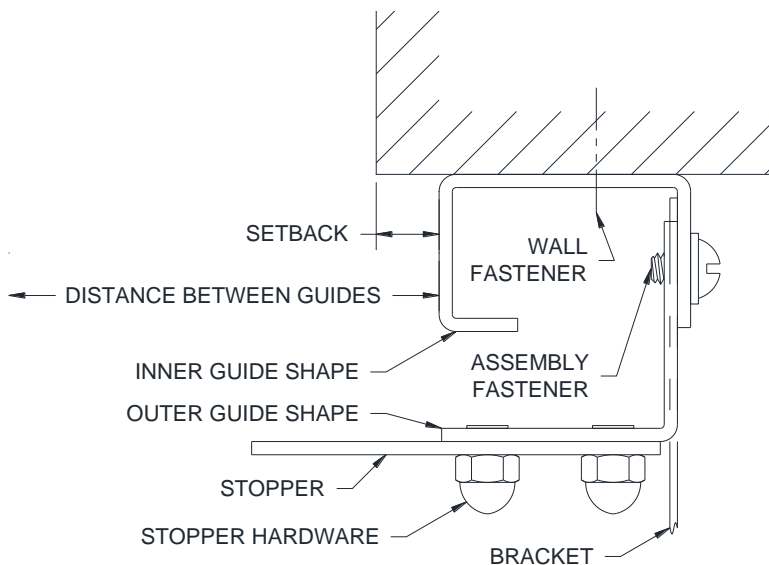

Figure 5.1 – UL9 Face of Wall Guide without Brush

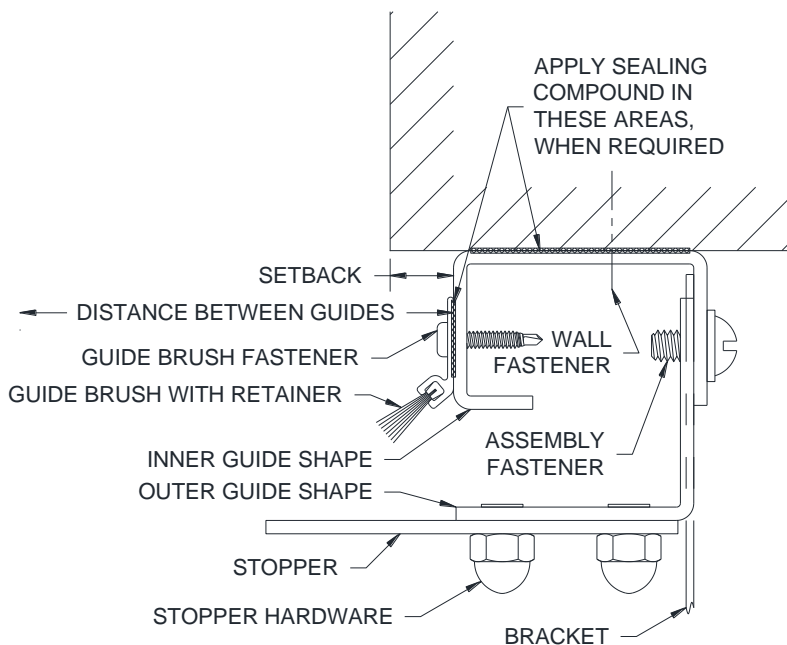

Figure 5.2 – UL9 Face of Wall Guide with Brush

¹ The guide assembly may differ from the right to left hand side of the unit. In these cases, follow the directions for each particular guide assembly, as well as the job construction drawings provided with the unit.

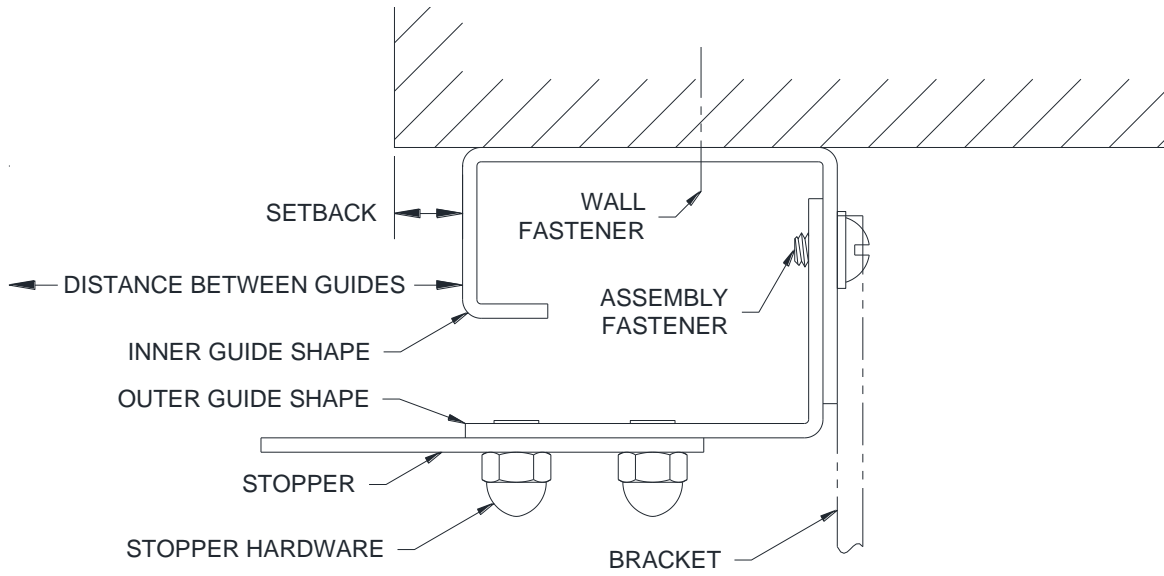

Figure 5.3 – UL10 Face of Wall Guide without Brush

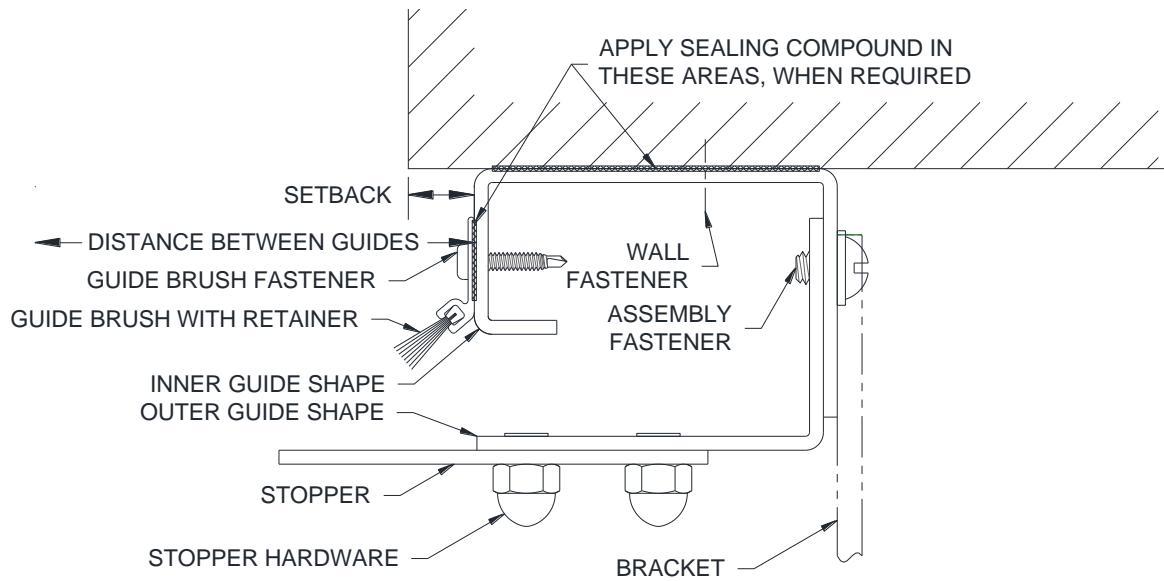

Figure 5.4 – UL10 Face of Wall Guide with Brush

1. Disassemble the inner and outer guide shapes. This is necessary to mount the inner shape to the wall.
2. If the guide is setback from the jamb:
 - a. Determine the required “*Setback*” dimension for each side of the unit from the job information. See **Figures 5.1-5.4** for visual reference of the “*Setback*” dimension.
 - b. Measure from the jamb to the inner guide shape.
 - c. Place a mark on the floor at measured location.
3. Measure the “*Distance Between Guides*” dimension. This is the distance between the inner guide shapes. See **Figures 5.1-5.4**. For guides with no setback, simply measure from jamb wall-to-jamb wall.
4. Ensure this measurement matches the “*Distance Between Guides*” dimension specified on the job construction drawings.
5. If the measurement does not equal the dimension on the job construction drawings, **STOP**. Check the guide dimensions against those on the job construction drawings to be sure the correct guides are being installed. If so, repeat previous step and re-check.

Note: *If the measurement is still not equal, contact the distributor.*

6. Place the inner guide shape(s) against the wall and plumb. Mark the location of the wall fastener holes.
7. Check the job construction drawings for the specified wall fasteners. Drill mounting holes for the wall fasteners. Fasten to wall using the provided fasteners.
8. Plumb the guide and tighten the wall fasteners to the recommended installation torque. See **Table 12.1**.
9. Do **not** attach the outer guide shape to the inner guide shape until the curtain is installed. The installation of the curtain will be much easier without the outer guide installed.
10. If a brush seal is required, attach it to the inner guide shape.

▪ **Between Jambs Units (Figures 5.5-5.8):**

Note: Determine the specified guide configuration for the door from the job construction drawings and compare to the diagrams below.¹

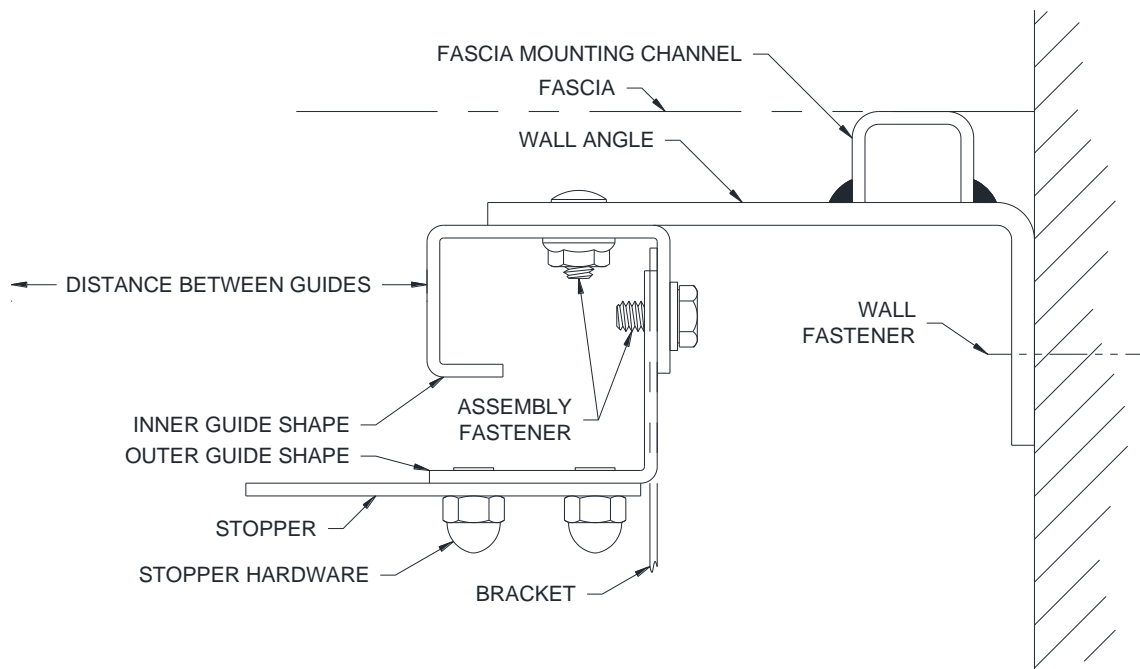

Figure 5.5 – UL9 Between Jambs Guide without Brush

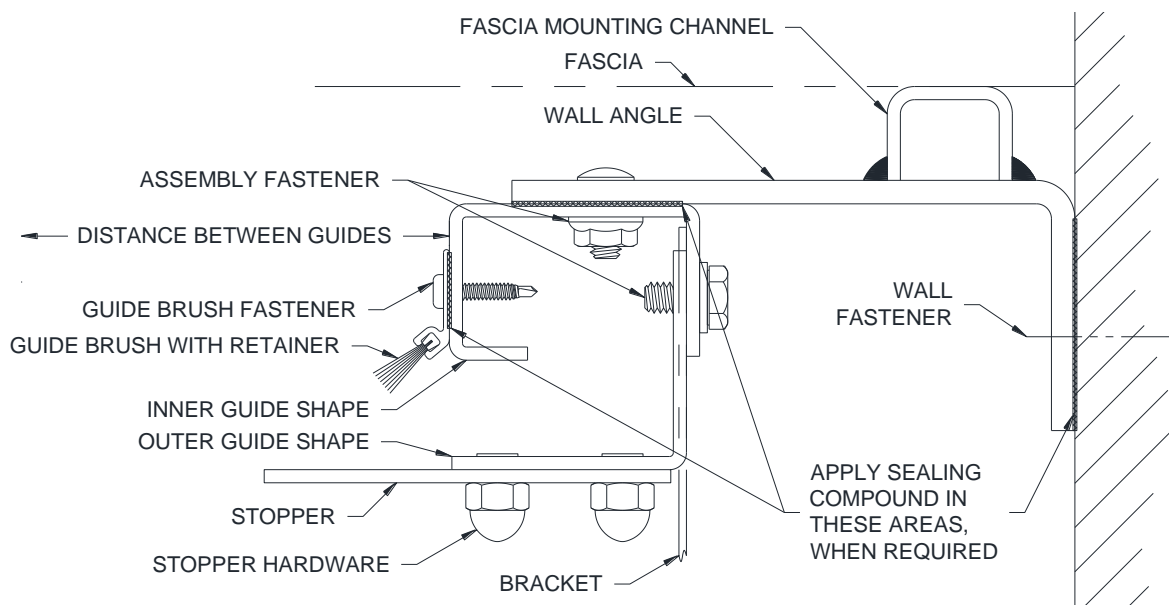

Figure 5.6 – UL9 Between Jambs Guide with Brush

¹ The guide assembly may differ from the right to left hand side of the unit. In these cases, follow the directions for each particular guide assembly, as well as the job construction drawings provided with the unit.

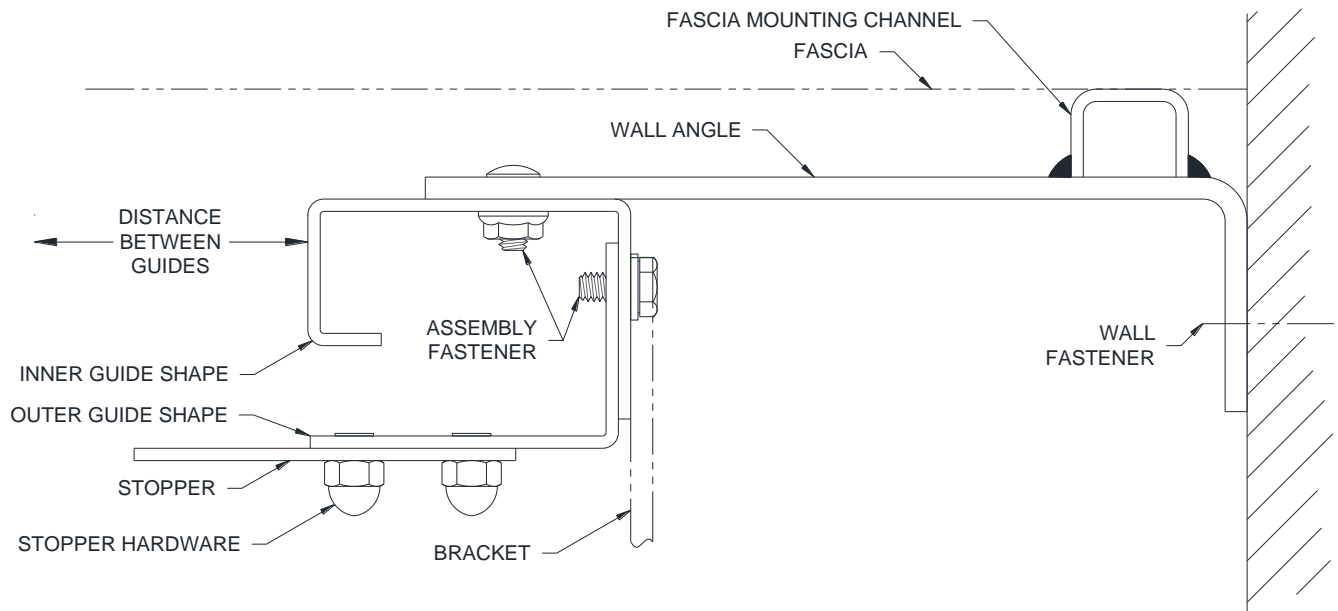

Figure 5.7 – UL10 Between Jamb Guide without Brush

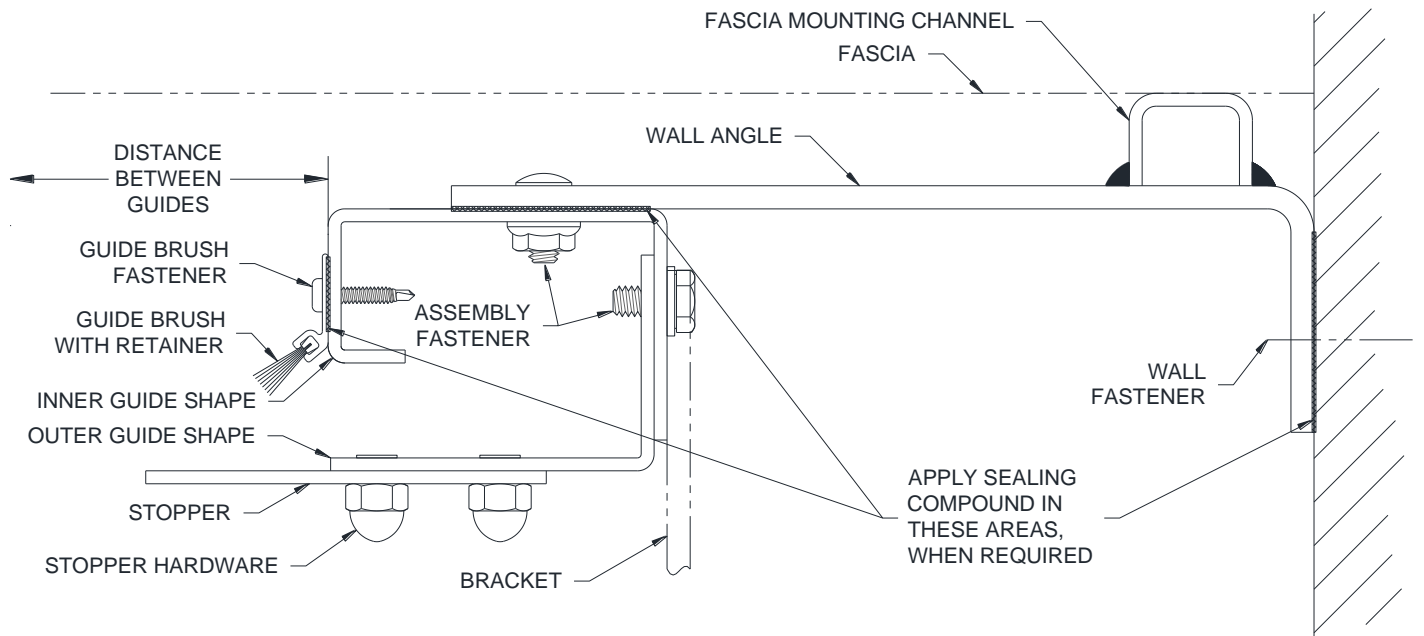

Figure 5.8 – UL10 Between Jamb Guide with Brush

1. Disassemble the inner and outer guide shapes, as well as the wall angle. Doing so will make it easier to maneuver the guide parts when locating the guide on the jamb.

Note: *It may not be necessary to disassemble the guides to install them, depending on the size of the unit. However if the guides are not disassembled, the stoppers will have to be removed to allow the curtain to be installed later on.*

2. Verify that the opening width matches the job construction drawings by measuring the distance between jambs. If this distance is not equal to the job construction drawing dimension, **do not proceed!!** Be sure the correct unit is being installed. Contact the project manager.
3. Use the job construction drawings to locate the guides on the jamb. Be sure to allow room for the fascia mounting channel that is welded to the wall angle. See **Figures 5.5-5.8**.
4. If a header/lintel exists, see the elevation view of the job construction drawings to determine if the door is to be placed against the header. If so, project a plumb line from the header to the floor. Mark the floor at this location.
5. If a header / lintel does **not** exist, or if the door is not going to be placed against the header / lintel, contact the project manager to determine where the door will be located. Mark the floor at this location and scribe a plumb line up the jambs.
6. Stand each wall angle up to its corresponding jamb. Use the markings made in the previous steps to locate and plumb the angle. Mark the location of the wall fastener mounting holes.
7. Check the job construction drawings for the specified wall fasteners. Drill mounting holes for the wall fasteners and fasten the wall angle with the provided hardware.
8. Plumb the wall angle and tighten the fasteners to the recommended installation torque in **Table 12.1**.
9. Attach the inner guide shape to the wall angle with the provided hardware. Preload the assembly fasteners to the recommended torque in **Table 12.1**.
10. Measure the "*Distance Between Guides*" dimension and compare it to the dimension specified on the job construction drawings. Refer to **Figures 5.5-5.8** for a visual representation of the dimension.

NOTICE

If the "*Distance Between Guides*" dimension does not equal the dimension on the job construction drawings, **STOP**. Check the guide dimensions against those on the job construction drawings to be sure the correct guide is being installed. If so, repeat the previous steps and check the "*Distance Between Guides*" dimension again.

11. Do **not** attach the outer guide shape to the inner guide shape until the curtain is installed. The installation of the curtain will be much easier without the outer guide installed.
12. If a brush seal is required, attach it to the inner guide shape.

- **Mixed Guides (One Face of Wall and One Between Jambs):**

1. Refer to the job construction drawings for specific mounting information.
2. Follow the steps in the preceding sections for each of the respective guide configurations.
3. Ensure that the guide centers (centerline of the guide openings) are aligned before proceeding.

▪ **Preparation of the Barrel and Brackets**

Note: Check to see if a hood support will be required. If so, refer to the “**Hood Support Installation**” section before proceeding to the barrel and brackets.

1. Refer to the job construction drawings to determine the “coil side” of the opening, or the side of the opening on which the coil is to be installed. Then determine which jamb wall is your “operator side”, or side on which the operator is to be installed. The following instructions refer to these directional cues.

Note: Units *without* operators (such as push-up units) are still considered to have an “operator” side. The shaft and job drawings will be marked with “operator” side regardless of the operation of the door so that it can be used as a directional cue.

2. Unpack the barrel assembly. Note the markings on the barrel, see **Figure 6.1** below.

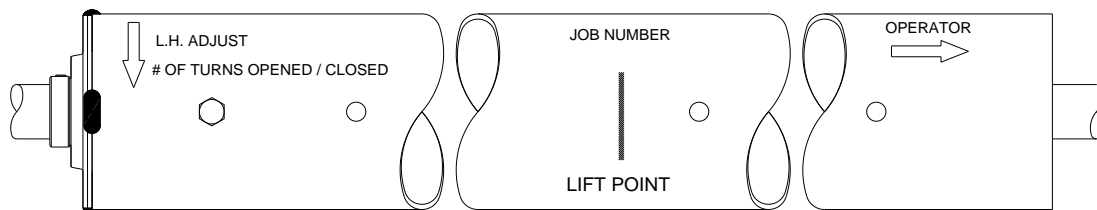

Figure 6.1 – Barrel Markings (Left Hand Adjust Shown)

3. Position the barrel assembly on the coil side of the opening, with the end marked “operator” towards the “operator side” of the opening. In order to alleviate the ring and bracket installation, place the barrel assembly on blocks or spacers such that it is elevated off the ground.

Note: Choose sufficiently sized blocks. The barrel assembly should be elevated off the ground enough that the brackets can be installed without contacting the floor.

4. Check to make sure the required number of turns is noted on the barrel, as shown in **Figure 6.1**. Consult the distributor or the manufacturer if you cannot locate this information. Check that these numbers match the information provided on the job information. Take note of these numbers, as access to this information may be obstructed once the curtain is installed.
5. Typically the adjusting wheel is not shipped attached to the barrel. However, if the adjusting wheel *is* attached to the barrel, remove by loosening the bolt or set screws that secure the adjusting wheel to the barrel and sliding the wheel off the inner shaft. See **Figure 6.2**.

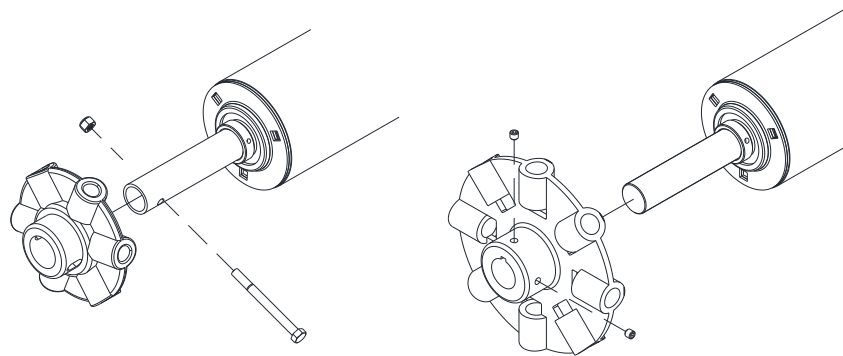

Figure 6.2 – Removal of Adjustor From Barrel Assembly

6. Refer to the job information provided with the door to determine the correct ring type and quantity.
7. Locate the rings in the hardware bag/box provided. Check that you were supplied the correct type and quantity. (Use **Figure 6.3** as a visual aid.)

8. Use the information in **Figure 6.3** to install the rings.

Note: It is **critical** that the rings are installed correctly in relation to the coiling direction, or the direction of wrap as the door travels upward. The rings act as graduated spacers, meaning they increase in diameter such that the curtain wraps in a consistent and smooth manner. Use the arrows on the figures below to determine the correct orientation of the rings in relation to the coiling direction.

SA0114 Extruded Rings:

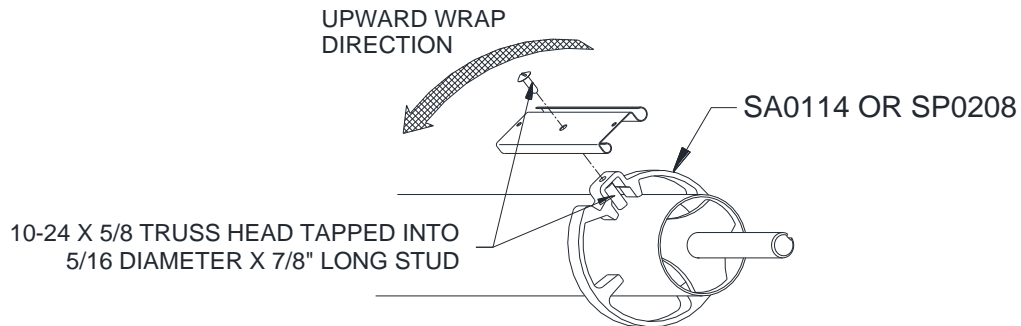

Installation:

- Slide the ring over the barrel, noting direction of wrap, and rotate the ring fits over the 5/16" diameter x 7/8" long stud that is welded to the barrel.
- At this time there is no additional assembly required until the curtain is to be fastened to the barrel. In which case, the fastening section slat is fastened to the barrel using the #10-24 screws provided.

SP0251 Cast Rings:

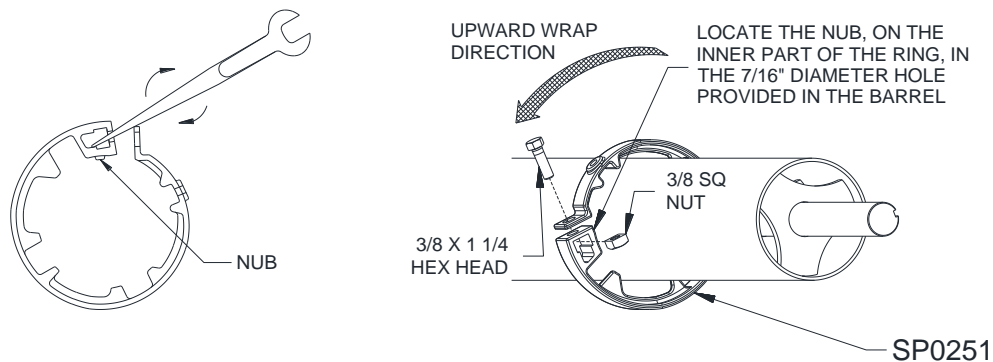

Installation:

- Use a small pry bar or large standard screwdriver to spread the gap in the ring by prying between bolt flange and the nut cradle of the casting (see above).
- Slide the ring over the barrel, noting direction of wrap, and rotate the ring so the locating nub in the casting aligns with the locating hole in the barrel.
- Insert the 3/8 square nut into the nut cradle of the casting and the 3/8" x 1-1/4" hex bolt through the bolt flange in the casting and tighten to minimum 20 ft-lbs of torque.
- Be sure ring sits straight on barrel.

Figure 6.3 – Ring Installation

9. Locate the brackets. Determine the "operator" and "adjustor" brackets by referring to **Figure 6.4**. The "operator" bracket may vary significantly based on the operation of the door. The "adjustor" bracket will contain a label with spring adjustment instructions.
10. Remove the adjusting wheel if you haven't previously done so, and slide the adjustor bracket over the inner shaft of the barrel assembly. The hood clip angles should be facing inwards. Install the adjusting wheel (see **Figure 6.2**).

11. If you have a conventional operator (with dropout pawl and fuselink), the operator bracket is shipped with a temporary plug holding the sprocket(s) and spacer washers in place on the bracket. Remove the plug and the bag of hardware attached to it, taking care not to lose the spacer washers positioned between the sprockets. Do not tighten the set screws in the bearing at this point. You may need to adjust the position when attaching to the guides.

Note: M100 and Push-up units will not have spacer washers, and will utilize only (1) sprocket on the "operator" bracket.

12. Align the bearing, sprocket(s) and spacer washers and slide the assembly over the gear end until the inside face of the bracket is approximately 3 inches from the edge of the outer shaft. It is recommended that you install the keys, located in the bag of hardware you removed with the temporary plug, into each sprocket at this stage. Do not tighten the set screws at this point.

Note: Do not install the operator until the barrel and bracket assembly is hoisted into position and securely fastened to the guides. Installing the operator prior to this stage will cause the assembly to be lopsided and cumbersome, making it difficult and potentially dangerous to hoist into position.

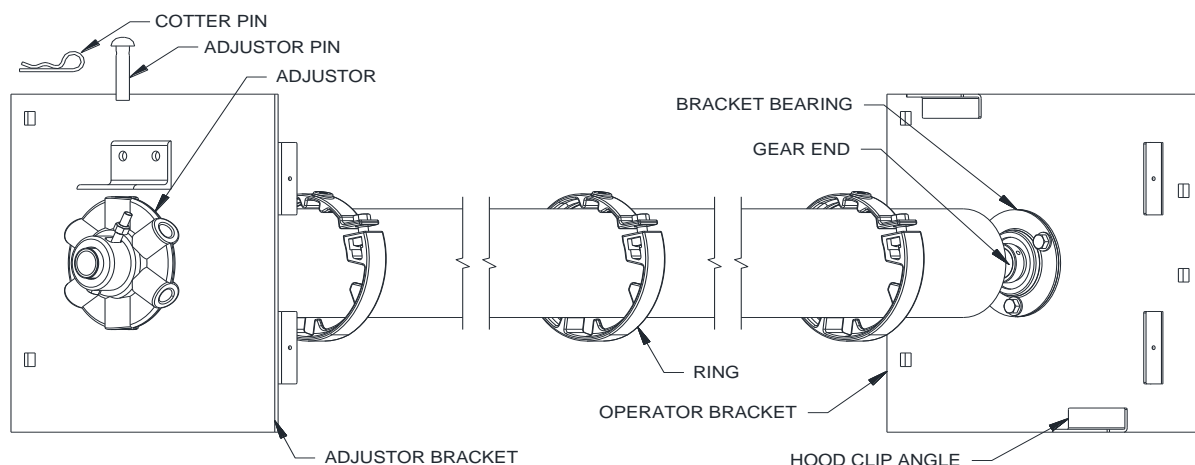

Figure 6.4– Brackets and Barrel Prior to Installation (M100 fire shutter brackets shown)

▪ **Hoisting and Installing Barrel Assembly**

1. The following methods can be used for hoisting them into place:
 - **Crane Hoisting:** Place a sling or lifting agent under the barrel assembly at the “lift point” provided on the barrel, see **Figure 6.1**.
 - **Forklift Hoisting:** Space the forks evenly under the “lift point” provided on the barrel, see **Figure 6.1**. Ensure that the barrel assembly is positioned close enough to the tips of the forks that the fastening holes in the bracket can be aligned with those of the guides without the forks contacting the wall. Secure the barrel assembly to avoid the slipping off the tip of the forks.

⚠ WARNING

The addition of brackets may offset the balance slightly from when the “lift point” was marked. Check to make sure the assembly is properly balanced before hoisting.

2. Before hoisting, refer to the hardware sheet and ensure that the proper type and quantity of fasteners were provided for the bracket installation.
3. Check the job construction drawing for the type of unit (*UL-9* or *UL-10*).
 - a. If you have a *UL-9* unit, measure the distance between the inside of the inner guide shapes.
 - b. If you have a *UL-10* unit, measure the distance between the outside of the inner guide shapes.
 - c. Measure the distance between the brackets and compare that to the distance measured to the inner guide shapes. See **Figures 6.5 and 6.6** below for bracket locations in relation to the guide shape.
4. Center the barrel assembly between the guides, keeping approximately 2 feet of clearance between the barrel assembly and wall/guides.
5. Raise the barrel assembly up to the approximate bracket mounting level. The brackets should be clear of the outer and inner guide angles.

Note: Position the brackets in the upright position, with the mounting holes facing the wall, before moving the assembly towards the wall. It may be difficult to rotate the bracket when in close to the wall.

6. Slowly maneuver the barrel assembly towards the guide, and align the mounting holes of the brackets with those of the inner guide shapes.
7. Insert the specified bolts and snug tighten, see **Figures 6.5 and 6.6**.

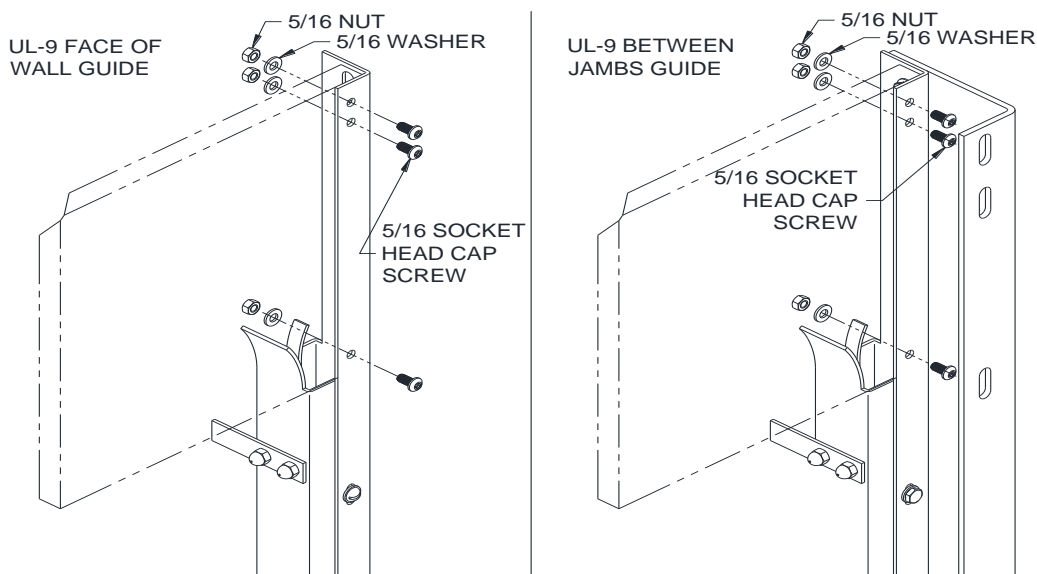

Figure 6.5– UL-9 Bracket Mounting and Hardware

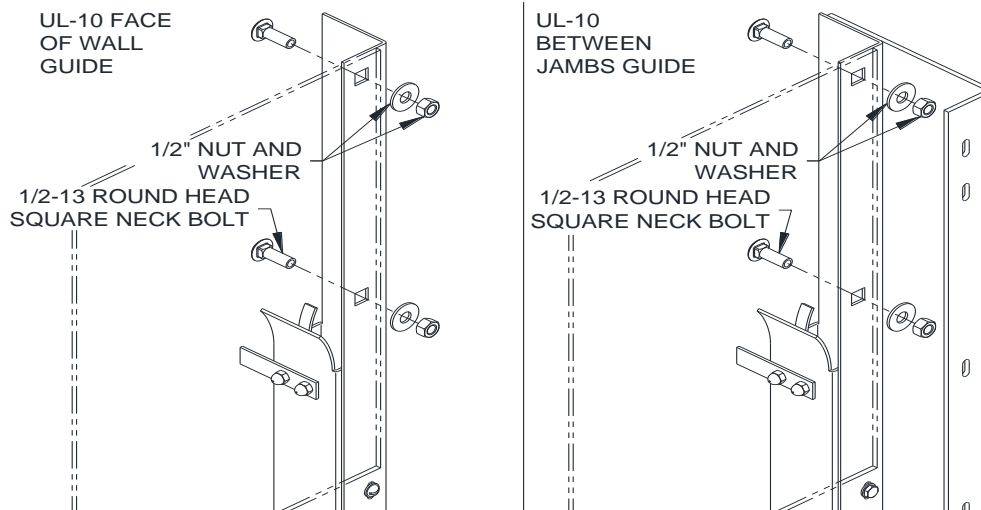

Figure 6.6– UL-10 Bracket Mounting and Hardware

8. Check to see that the barrel is positioned properly between the brackets. That is, so that the proper amount of space is allowed between the barrel and the brackets. Typically the space is equal at both the operator and adjustor side. Adjust as necessary.
9. Place a level in the center of the barrel. If the shaft is not level:
 - Check the dimensions of the brackets from the top of the bracket to the center of the barrel.
 - Verify that the bracket mounting fasteners are the same distance from the top of the bracket.
 - a. If the dimensions **are not** correct, contact the Service Department.
 - b. If the dimensions **are** correct, the floor may be out of level, causing the bracket mounting holes in the guides to be out of alignment.
10. Fully tighten mounting bolts to the torque specifications in this manual. See **Table 12.1**.

NOTICE

Proper pretension of the bracket mounting bolts will benefit the life of the bolts and brackets.

11. If the adjusting wheel was not previously installed, install it now. Do not install the adjustor pin yet.
12. Ensure the sprockets on the operator bracket are aligned as shown in **Figure 6.7**. Tighten the set screws in the sprockets and bearing.

Note: M100 units do not have brackets with multiple sprockets or gear trains that require alignment.

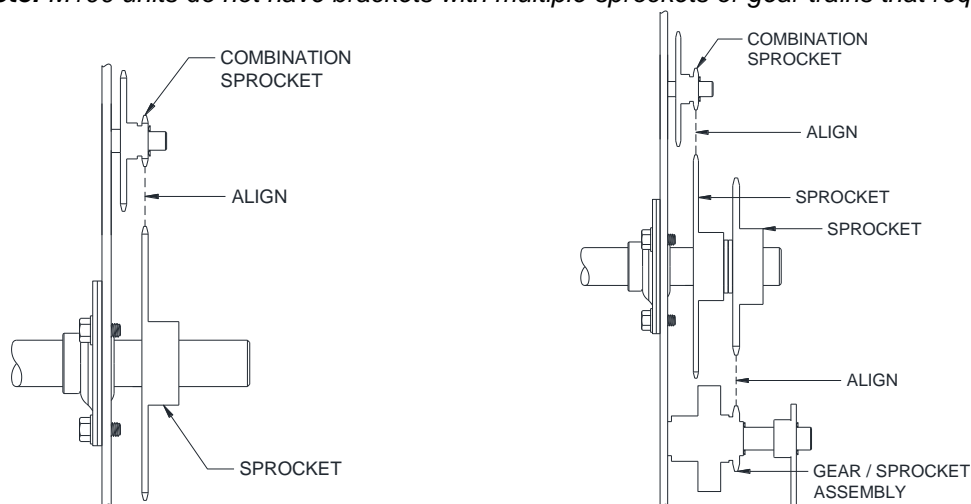

Figure 6.7– Conventional Fire Shutter Sprocket Alignment for Push-up Units (shown on left) and Motor Chain and Crank Units (shown on right)

▪ **Motor Operator Installation (if required):**

1. Unpack the motor operator from the shipping box and retrieve the *Operator Mounting Bracket* and bolts provided in the kit.
2. There are a few motor mounting configurations that can be formed with the supplied components. Refer to the shop drawings and components supplied with the kit in order to identify the specific style of mounting ordered for the unit. Some of the types of mounting are:
 - Vertical Bracket
 - Wall Mounting
 - Horizontal Front of Coil
3. Mount the operator mounting bracket to the operator using the supplied fasteners.
4. Mount the operator-mounting bracket to the operator bracket according to the shop drawings using the supplied fasteners.
5. Install controls and wire the operator. Refer to the wiring diagram provided with the operator for proper connections and voltages. The controls should be installed in an area from which the door/opening is clearly visible. This will allow an individual operating the unit to make a visual inspection of the opening for any obstacles or other potential hazards before setting the door into motion.

Note: Do not attempt to set the upper and lower limits until the curtain is installed.

▪ **Attaching Additional Bracing (if required):**

1. Attach a clip angle to the operator mounting bracket and the bracing angle to the clip angle. Snug all bolts.
2. Mount the other supplied clip angle to the bracing angle and swing the bracing angle to the wall or structural support.
3. Align the mounting face of the clip angle with the face of the wall, mark and drill a mounting hole for the size of the supplied mounting fastener, and secure the clip angle to the wall with the fastener.
4. Square the operator-mounting bracket, adjusting the bracing angle as necessary, and fully tighten all the mounting bolts.
5. Lift the motor operator into position on the mounting bracket and align it with the appropriate hole pattern. See **Figure 7.1** for operator mounting details.
6. Insert the fasteners included in the kit from the bracket side first into the mounting foot of the operator and tighten the nuts with lock washers.

Note: All mounting bolts are supplied with nuts and lock washers.

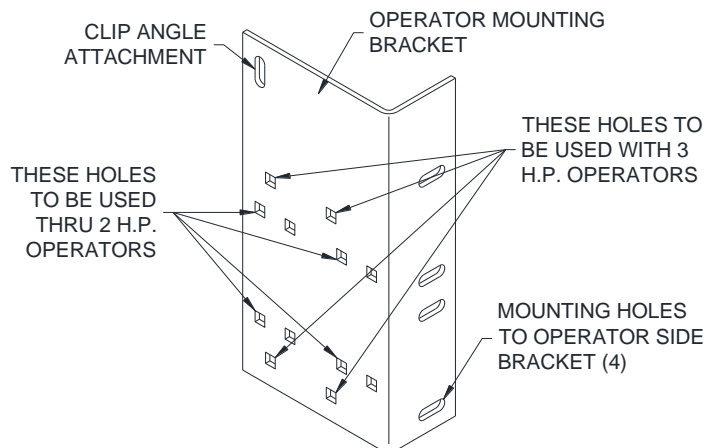

Figure 7.1 - Additional Operator Bracing

▪ **Curtain Installation**

1. Remove the stoppers from the guides, or position them so they do not protrude into the opening.
2. Open the curtain packaging. Leave the plastic straps that keep the curtain from uncoiling in place. It may also be beneficial to leave some of the packaging under the curtain to protect the finish during installation.
3. The coil will be provided with the top of the curtain on the outside, thus leaving the fastening sections exposed. Position the coil on the floor between the guides so that the open end of the fastening sections is facing up and nearer the wall.
4. Remove the outer guides.
5. Locate the curtain attachment hardware provided with the unit. Refer to the job information to ensure you have the correct type and quantity.
6. Lift the coil until it is just below the shaft. Using appropriately rated ropes or straps, sling the coil from the shaft as shown in **Figure 8.3**. Remove the plastic strapping securing the coil at this point.
7. Uncoil the curtain enough for the fastening sections to reach the attachment points on the shaft. Fasten them by aligning the fastening section with the hole in the ring or shaft respectively, and fasten using the provided hardware (see **Figures 8.1 and 8.2**). If the curtain is too heavy to uncoil by hand, use the method described in the following step to get the fastening sections in position.

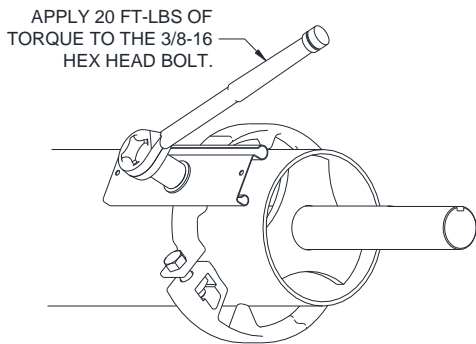

Figure 8.1 - UL-10 Fastening Section Attachment

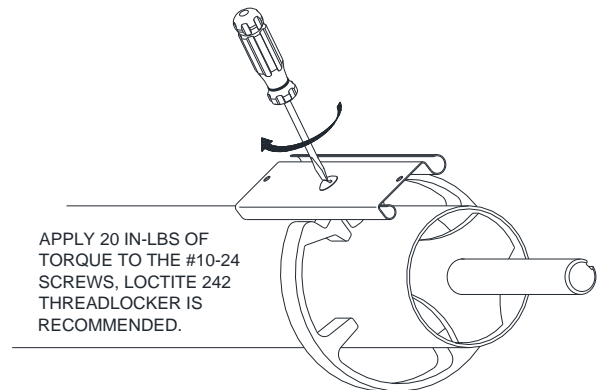

Figure 8.2 - UL-9 Fastening Section Attachment

8. Uncoiling a slung curtain using the operator/adjusting wheel:
 - For units with operators, use the hand chain, crank or override feature of the motor to rotate the shaft in the “open” direction. Be sure not to overrun the limits of the motor. The upper motor limit may have to be adjusted to reel the entire curtain onto the shaft. Make sure the adjusting wheel is **not** pinned in place for this operation.
 - For push-up units, turns can be added to the adjusting wheel in order to assist in rotating the shaft. Keeping count of the turns added to the spring at this stage will save installation time later.
9. Continue to rotate the shaft, reeling the curtain out of the sling and onto the shaft until the bottom bar reaches the bottom of the bracket.
10. Replace the outer guides.
11. Feed the bottom bar into the guides and lower the curtain until the bottom bar is below the stopper location.
12. Since there is no spring tension holding the curtain open, the curtain may fall if released. If the operator cannot be used to hold the curtain in the open position, place C-clamps or vice grips on the guides just below the bottom bar - *or*- rest the bottom bar on the slings used to hang the shaft in the previous steps to hold the door open.
13. Replace the stoppers.

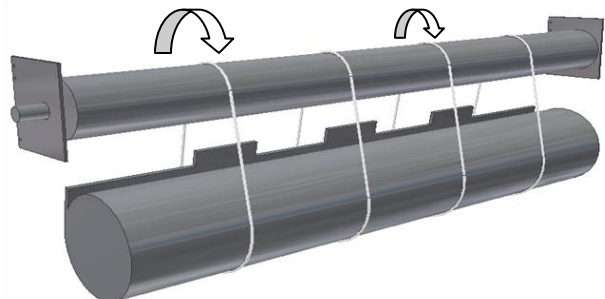

Figure 8.3 - Installing the Curtain

▪ **Applying Spring Turns:**

1. Refer to the job information or markings on the shaft for the number of spring turns required on the unit.
2. To apply spring charge, remove cotter and stop pin from adjusting wheel. Lower the Dropout Pawl for Conventional units (non-M100).
3. Using two ½” diameter steel rods, approximately 18” long, apply spring torque by inserting both rods into adjuster wheel one above the other.
4. Rotate wheel in a direction of raising the curtain. Maintain applied torque with upper rod, while removing lower rod. RE-insert this rod above the other and continue applying torque one notch at a time using this hand over hand procedure until the specified number of spring turns has been applied.
5. Replace stop pin into adjuster wheel as shown in **Figure 9.1** and insert the cotter pin to hold it in place.
 - If you have an M100 unit, move on to step 6.
 - If you have a Conventional unit, raise dropout pawl to engage with stop pin. Temporarily secure dropout assembly in position with C-clamp or vise grips until the final spring tension adjustment is completed and fusible link chain has been installed.

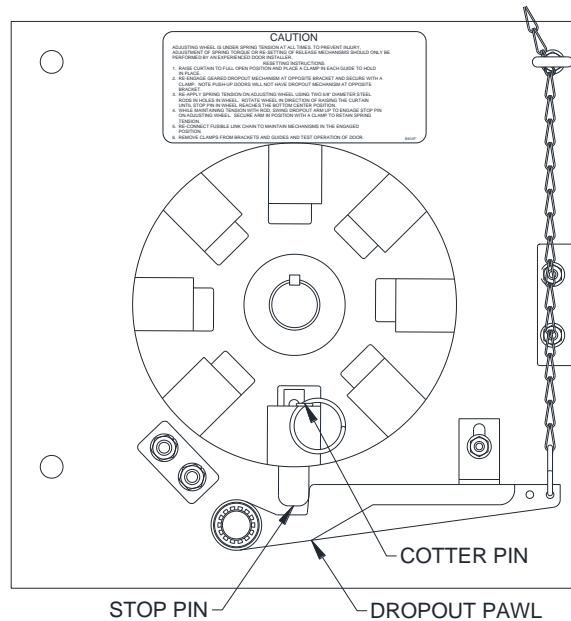

Figure 9.1 - Spring Release Assembly for a Conventional Fire Shutter

6. The spring should now hold the door in the open position. Remove any devices applied to hold the door in the open position (clamps, slings, etc.)
7. Check curtain for ease of operation. If the door operates correctly, skip to the fusible link setup, if not, continue to the next step.
8. Final spring tension adjustment, if necessary, should be increased or decreased with the curtain in the fully open position. Insert one [two if necessary] ½” diameter steel rods into adjuster wheel.
9. Holding the rod(s) firmly, disconnect the dropout assembly and lower until it clears stop pin on the adjuster wheel.

Note: M100 units do not require a dropout assembly.

10. Remove cotter pin and stop pin from adjuster wheel and begin to increase or decrease tension.
 - To increase tension, rotate the wheel in the direction of raising the curtain.
 - To decrease tension, carefully rotate the wheel in the direction of lowering the curtain.
11. Recheck the balance in 1/8 rotation increments (one notch at a time). Re-insert stop pin, cotter pin and engage dropout assembly into operating position immediately after each turn.

Note: If you have difficulty balancing the door, or the number of turns required to balance the door varies significantly from the quantity provided, contact the **Service Department**.

2. Refer to **Figure 9.3** and the job construction drawings for fusible link installation for **M100** fire doors.

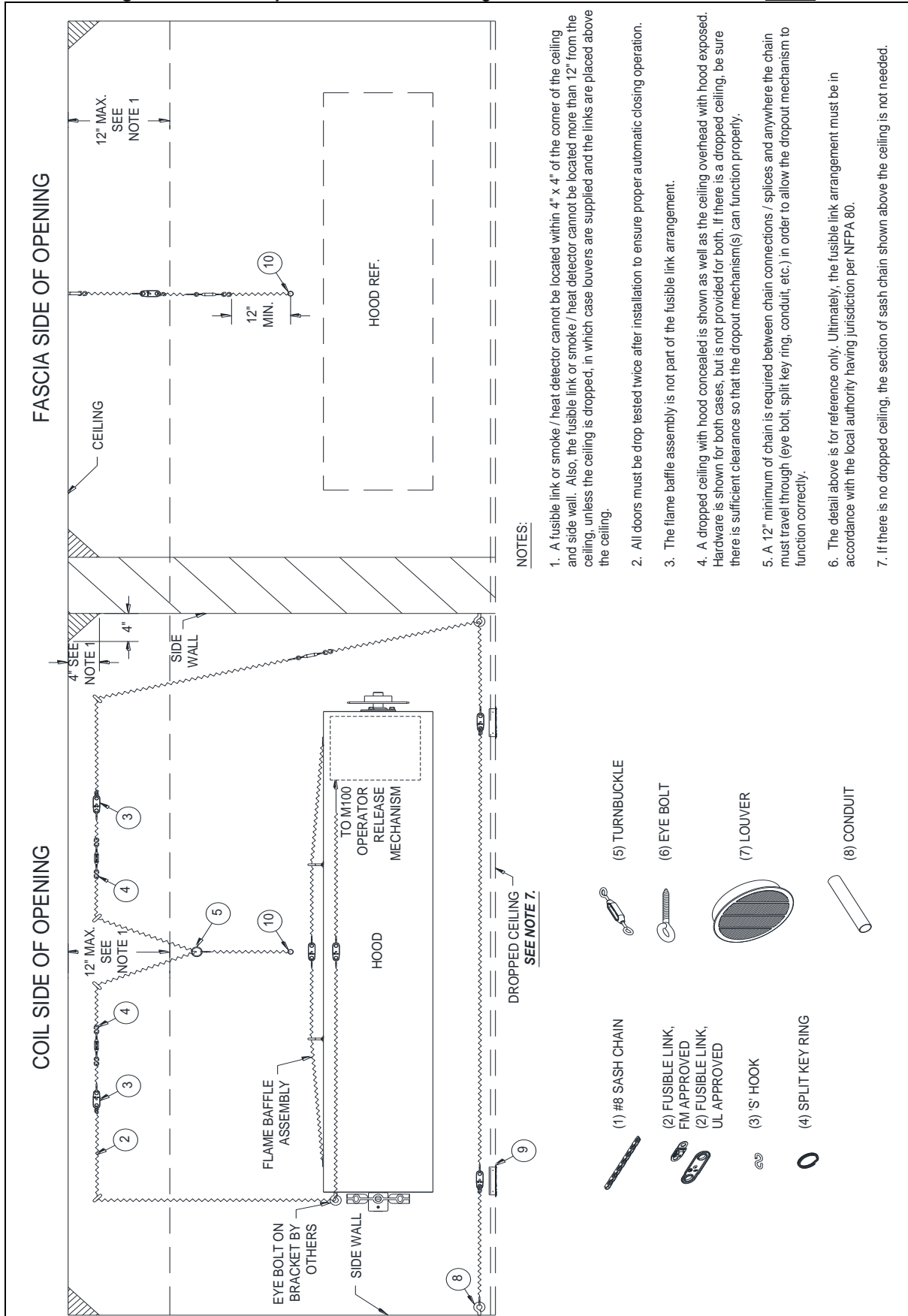

Figure 9.3. Fusible Link Installation for M100 Fire Doors

NOTES:

1. A fusible link or smoke / heat detector cannot be located within 4" x 4" of the corner of the ceiling and side wall. Also, the fusible link or smoke / heat detector cannot be located more than 12" from the ceiling, unless the ceiling is dropped, in which case louvers are supplied and the links are placed above the ceiling.
2. All doors must be drop tested twice after installation to ensure proper automatic closing operation.
3. The flame baffle assembly is not part of the fusible link arrangement.
4. A dropped ceiling with hood concealed is shown as well as the ceiling overhead with hood exposed. Hardware is shown for both cases, but is not provided for both. If there is a dropped ceiling, be sure there is sufficient clearance so that the dropout mechanism(s) can function properly.
5. A 12" minimum of chain is required between chain connections / splices and anywhere the chain must travel through (eye bolt, split key ring, conduit, etc.) in order to allow the dropout mechanism to function correctly.
6. The detail above is for reference only. Ultimately, the fusible link arrangement must be in accordance with the local authority having jurisdiction per NFPA 80.
7. If there is no dropped ceiling, the section of sash chain shown above the ceiling is not needed.

▪ **Installing through wall conduit for fusible links:**

Note: Read these instructions carefully before installing through wall conduit.

1. When a through wall fusible link is specified the hardware package will be supplied with a length of 1/2" EMT conduit and two 3/4" diameter set screw collars to secure the sleeve in the wall.
2. Determine the location where the conduit is to be installed and mark the wall. For information on location of conduit and fusible links refer to NFPA 80 Standard for Fire Doors and Other Opening Protective's.
3. Drill a 3/4" diameter hole straight through the wall at the location required for the through wall conduit installation.
4. Install one of the set screw collars on the end of the 1/2" diameter EMT conduit supplied with the hardware so the end of the conduit is back slightly from the face of the collar and tighten set screw.
5. Insert the conduit into the hole drilled in the wall and install the other collar on the conduit on the opposite side of the wall so the collars on both sides are against the face of the wall and hold the conduit securely in place.
6. Mark the conduit at the second collar so it can be cut to the proper length so both ends are back slightly from the faces of the collars.
7. Remove the conduit assembly from the hole through the wall and trim off the excess length at the location marked.
8. With a circular file or de-burring tool clean up both ends of the conduit so there are no sharp edges that can obstruct the proper operation of the fusible link setup.
9. Reinstall the conduit assembly in the wall as described in steps 4 and 5 and tighten the set screws to secure the conduit in the wall.
10. Install the through wall fusible link setup once the door installation is complete.

NOTICE

Once the fusible link setup is installed the conduit must not be plugged with fire-stopping products or other sealants that may obstruct proper operation of the fusible link system.

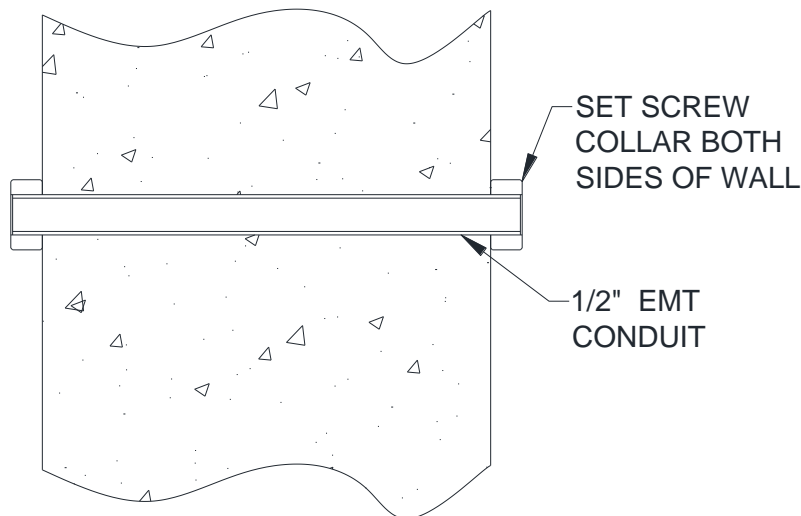

Hood Support Installation:

1. Determine what type of hood support is required and how many there will be. See below for different types.
 - a. Hood supports will be noted on the elevation view of the job construction drawings.

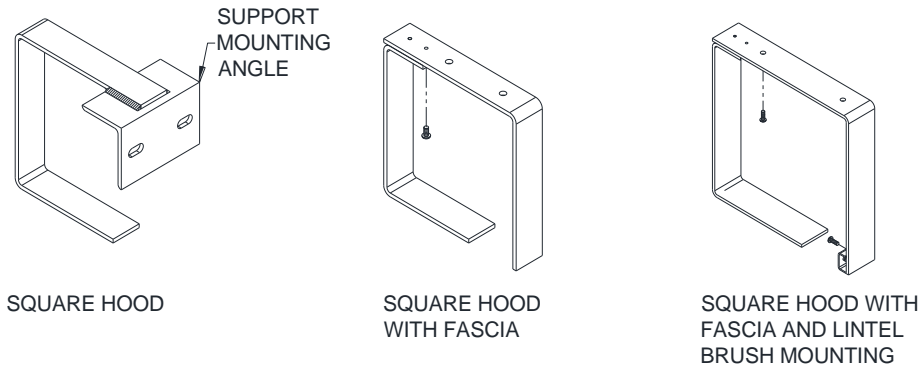

Figure 10.1 - Hood Supports

2. If a lintel brush is required, install it at this time. **Figure 10.2** below shows a lintel brush mounting with a hood support with the brush mounting modification.
3. See Figure 11.3 for mounting the lintel brush channel to the guide.

Note: Be sure the lintel brush does not interfere with the bottom bar.

4. Determine where the support(s) will be located between the guides.
 - a. If multiple supports are required, see the job construction drawings to determine the centerline of each.
 - b. If a single support is required, it will be located at the center of the unit.
5. Mark a line on the lintel or ceiling (for units without a lintel) at the centerline of each support.
6. Check the construction at the support locations to be sure it is strong enough to handle the weight of the hood.

Note: If the construction is not strong enough, do not proceed until rectified.

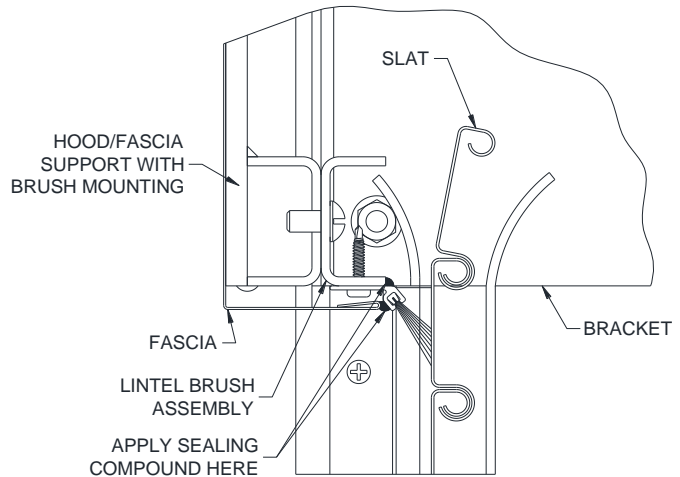

Figure 10.2 - Lintel Brush Channel Mounting to Hood Support

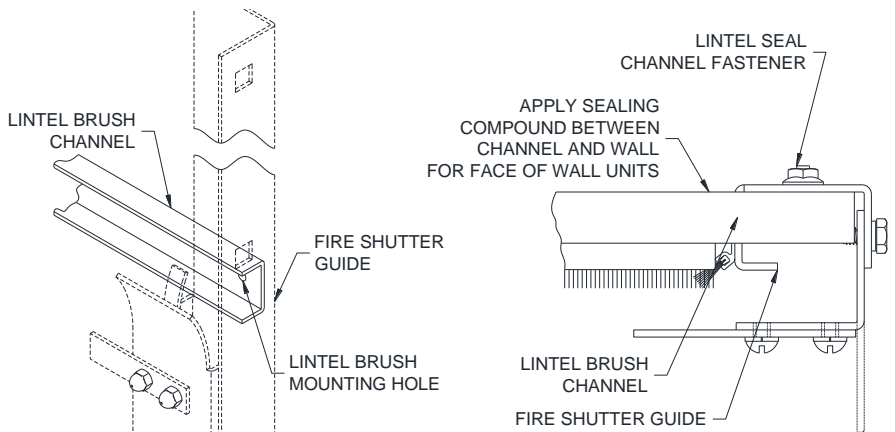

Figure 10.3 - Lintel Brush Channel Mounting to Guide

7. Determine where the top of the coil will be.
 - a. This is typically at the top of the wall angle or intermediate angle.
 - b. If there is no wall or intermediate angle, see the job construction drawings for the distance from the bottom of the unit to the top of the coil.
 - c. If there is a ceiling at the top of the coil, skip the next step.
8. Mark a line at the top of the coil at both guides of the unit. Project the lines together to make a continuous line. This will help locate the top of the hood support which will keep the hood level.
9. If there is no lintel/header, the hood support will be located based on the fascia side of the guide.
 - a. If the unit is between jambs with 4 angle guides, a fascia mounting channel is typically provided.
 - b. If the unit is between jambs with 2 angle guides mounted to a tube, a fascia mounting channel is not provided, and the fascia is mounted to the fascia side of the tube.
10. Project a line from the fascia mounting location (fascia mounting channel or fascia side of the tube) from one guide to the other.
11. Mark a line at the support centerline along the fascia line.
12. Prepare the location of the attachment point of the support(s) prior to installing the barrel. This will make installing the support much easier when the time comes to attach it to the lintel/header or ceiling.
 - a. Hold the support in place at the determined location and mark the mounting hole locations.
 - b. Drill holes in the construction.
13. Attach the hood support to the lintel/header or ceiling to be sure the mounting holes were located properly.
14. Remove the hood support and proceed to the **“Barrel and Brackets”** section.
15. Once the barrel, brackets, curtain are installed, and necessary testing was done on the unit, re-install the hood support.

▪ **Hood and Fascia Installation:**

1. Check the job construction drawings to see if the hood has multiple parts (such as a two sided hood with a fascia, two sided hood without a top piece, three sided hood with a flared top bead, etc). See **Figure 10.4** for possible hood configurations.
2. Fasten the hood and fascia accordingly using the fasteners provided. Ensure hoods with multiple sections overlap correctly. Square hoods should end flush with the outer edge of the brackets.
3. If there is a hood support provided, the hood sections do **not** overlap at the hood support. They should butt against each other and a hood splice cover is provided to cover the joint.

Note: If there is a hood support, pre-drill holes in it to ease hood attachment. A #21 drill size is recommended.

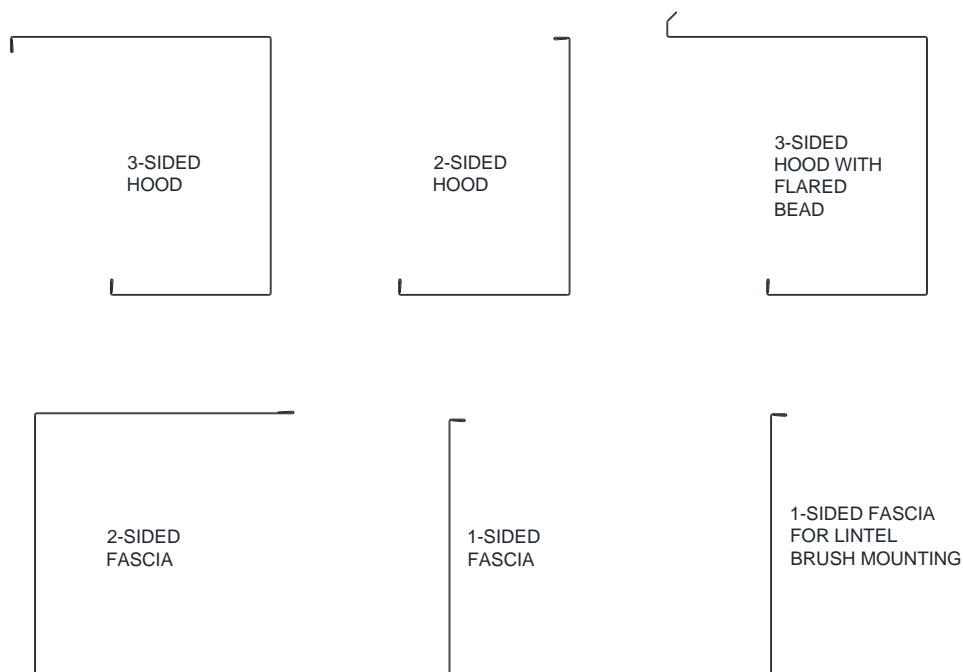

Figure 10.4 - Hood Configurations

▪ **Cover installation:**

1. Once the unit is installed and operating correctly, the covers can be installed.
2. Hood screws may have to be removed and reinstalled to install covers properly.

Note: Mechanism covers are required on all conventional fire doors to prevent dropout mechanisms from being obstructed. These covers are optional on M100 fire doors.

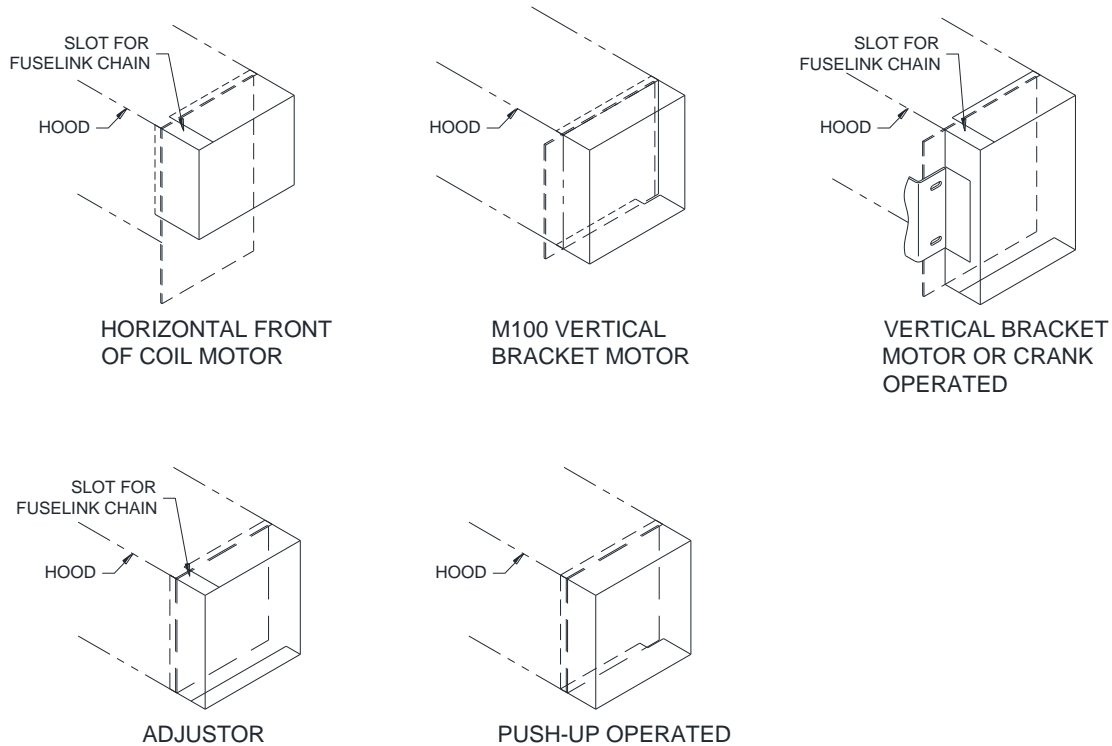

Figure 10.5 – Mechanism Covers

Note: Mechanism covers differ from operator and adjustor covers in that operator and adjustor covers provide a complete enclosure.

3. If an operator or adjustor cover is provided, individual installation instructions are provided with each cover along with the necessary hardware to attach the cover.
4. Once the cover is installed, operate the door a few more times to be sure there is no interference between the moving components inside the cover and the cover itself.
5. If the door is mounted on the exterior of the building, a bead of silicone sealant should be applied around the entire perimeter of the cover, as it will provide additional protection to the door components.

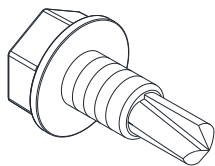

Figure 10.6 – Hood and Cover Screw (#10-16 x 1/2")

▪ **Drop Testing:**

Note: Perform door and electrical operator maintenance. It is important to make sure that the door operates properly in the normal mode of operation before testing the automatic closing mechanisms.

1. Inspect the fusible links and chain arrangements. Links and chain should be clean and unpainted. Links and "S" hooks should be at least 12" away from any eyebolts or thru wall fixtures to insure enough chain travel for mechanisms to drop out. Check for any other points where the chain may hang up.
2. Check release arms on brackets. Make sure that they are NOT tied up in place and that nothing will block proper drop out of arms.
3. The door should be drop tested twice. The first test should ensure the proper operation of the closing mechanism and full closure of the opening. The second test should verify that the automatic-closing device has been reset correctly (reference NFPA 80).
4. Drop test door to check automatic closing mechanism. Make sure that the door is in full open position. Initiate automatic closing by separating the chain at the "S" hook. Door closing speed shall not be less than 6" per second nor more than 2' per second. The door must close completely with the bottom bar resting on the sill.
5. If problems occur during the drop test, consult installation instructions or door manufacturer.
6. Reset door mechanisms following manufacturer's instructions.
7. A second drop test should be performed. This one should be witnessed by a representative of the owner.
8. Reset door.
9. Door releasing devices, smoke detectors and other special control equipment may be tested if owner requests. Follow manufacturer's instructions for testing. If smoke detectors are connected to a central fire alarm system, they should not be tested.
10. When repair parts are required, they must be purchased from the original door manufacturer.

The following documents should have been provided with the Fire Door:

- **Rolling Steel Fire Doors Drop Testing and Annual Follow-Up Owners Guidelines**
- **Rolling Steel Fire Door Initial & Annual Drop Test Form**

If you cannot locate these documents, or need replacements documents, contact the Service Department.

Torque Specifications

Table 12.1 – Torque Recommendations for Guide Assembly and Wall Fasteners

Bolt size/type	Torque (ft lbs) ^a
1/4-20 Grade 2 steel bolt	6
5/16-18 Black Oxide Socket Cap	25
3/8-16 18-8 stainless steel bolt	20
3/8-16 Grade 2 steel bolt	20
3/8-16 Grade 5 steel bolt	31
1/2-13 Grade 5 steel bolt	75
1/2-13 Grade 8 steel bolt	107
5/8-11 Grade 8 steel bolt	212
3/4-10 Grade 8 steel bolt	376

^a The recommended torque for steel bolts is based on a plated bolt that has not been lubricated.

Table 12.2 – Torque Recommendations for Solid Masonry Wall Anchors

Anchor Size (nominal)	Manufacturer / Torque (ft lbs) ^a	
	Simpson Wedge-All	Hilti-Kwik Bolt 3
3/8	30	20
1/2	60	40
5/8	90	85
3/4	150	150

^a Torque values for grout filled block are different, reference bolt manufacturer for these values.

Maintenance Schedule

▪ **Maintenance Schedule:**

Note: If any of the following problems exist, **do not** operate the door until repaired.

Component	What to look for and how often the components must be inspected:	Weekly	Monthly	Quarterly	What to do if problem exists:
Curtain & Bottom Bar	Are any curtain components damaged (slats, endlocks, etc.)?	X			Contact Service about replacing damaged parts.
	Is bottom bar damaged?	X			Contact Service about replacing damaged parts.
	Are bottom bar fasteners in place and properly tightened?		X		Fasteners must be inspected/replaced and properly tightened.
	Are fasteners attaching curtain to the barrel in place and properly tightened?		X		Fasteners must be inspected/replaced and properly tightened.
	Do you notice any hang-ups, jamming or other problems preventing the door from moving smoothly throughout the opening?	X			Check for external issues, if none exist, contact Service.
	Do you notice any odd or excessive noise when the door is operated?	X			Check for external issues, if none exist, contact Service.
	If there is a bottom seal, is it damaged?		X		Contact Service about replacing damaged parts.
	If there is locking, does it function properly?	X			Check for external issues, if none exist, contact Service.
Brackets	Are brackets plumb and perpendicular with wall?			X	Contact Service.
	Are bracket fasteners in place and properly tightened?			X	Fasteners must be inspected/replaced and properly tightened.
	Do you notice signs of excessive wear on the bearings (i.e. binding, excessive noise, etc.)?		X		If there is a grease fitting, apply grease, if not, contact Service.
	Is adjusting wheel & pin secure?			X	Contact Service.
	Is drive chain sufficiently lubricated?			X	Apply chain lube.
	Is drive chain in need of tightening?			X	Contact Service for instructions on how to tension the chain.
	Is drive or driven sprocket damaged?		X		Contact Service about replacing damaged parts.
Guides	Are wall fasteners in place and properly tightened?		X		Fasteners must be inspected/replaced and properly tightened.
	Are guide assembly fasteners in place and properly tightened?		X		Fasteners must be inspected/replaced and properly tightened.
	Is guide gap dimension correct?		X		Check job construction drawings and adjust gap as required. If job construction drawings are not available, contact Service.
	Are any of the guide parts bent or damaged?		X		Contact Service.
	Are stoppers loose, damaged, or missing?		X		Stoppers must be inspected/replaced and properly tightened.
Hood and Fascia	Is hood/fascia dented or damaged?			X	Remove hood/fascia. Repair if possible. If not leave hood/fascia off and contact Service.
	Is curtain rubbing against the hood/fascia?	X			Hood/fascia may have been damaged. Contact Service.
	Is hood/fascia level?			X	Check fasteners, they may be loose or missing. Replace as soon as possible.
	Are guide assembly fasteners in place and properly tightened?		X		Fasteners must be inspected/replaced and properly tightened.
	Is hood support level?			X	Check fasteners, they may be loose or missing. Replace as soon as possible.

Maintenance Schedule

Door operation	Does the door require excessive force to open?		X		Check for hang-ups or obstructions. Ensure spring tension is set correctly. Contact Service.
	If the door contains locking, does the locking mechanism function properly and securely hold the door in the closed position?		X		Check for damage and other external issues. Contact Service.
	If there is a sensing edge, does it function properly?	X			Cut power and check for loose wires. Contact Service for further instruction.
Motor Operator	Are the fasteners attaching the motor-to-the mounting bracket, and mounting bracket-to-the door bracket secure?			X	Fasteners must be inspected/replaced and properly tightened. Contact Service for replacement hardware.
	Are the sprockets properly aligned?			X	Realign the sprockets as secure using the set screws. Recheck chain tension.
	Are the sprocket keys properly aligned with sprockets and securely fastened with the set screws?			X	Reposition the keys so they fully engage the keyway in the sprocket. Tighten the set screws.
	Is the door stopping correctly at the open (before bottom bar contacts the stoppers) and closed (as soon as the bottom bar contacts the floor) positions?		X		Limits may have to be adjusted in the motor operator. Refer to the operator owner's manual or contact Service.
	Is the operator functioning normally?		X		Refer to the <i>Operator Troubleshooting Table</i> on the following page to diagnose the problem.

Maintenance Schedule

▪ **Operator Troubleshooting:**

Note: If you suspect you are having an issue with your operator, use the following table to determine the potential causes. If the provided solution does not eliminate the issue, or the table does not address your particular problem, contact the Service Department.

Component	Problem	Potential Cause	Solution
Motor Operator	Motor Operator does not run when OPEN or CLOSE button is pushed	The circuit breaker may be flipped or fuse blown.	Reset breaker or replace fuse. Contact Service if replacement fuse is needed.
		The thermal overload may be tripped.	Reset thermal overload.
		Manual interlock switch is open (on units with emergency operator).	Close manual interlocks.
		External interlock may be opened.	Close external interlock.
	Motor operator runs but the door does not move	Sprocket key may be missing or drive chain may be broken.	Contact Service for repair parts. Install key or replace chain.
		Clutch may be slipping.	Adjust if possible. Contact Service otherwise.
	Motor hums but does not run	Door or drive chain may be jamming.	Check for hang-ups or obstructions. Try to operate manually. If issue persists, contact Service.
		Dead phase in 3 phase system.	Check power supply.
		Brake does not release.	Check power to brake solenoid.
		Open motor winding.	Check that all connections are secure.
	Motor operator runs in wrong direction and limits do not function	3 phase operator power supply is out of phase.	Interchange any 2 power leads to unit.
	Door drifts when motor shuts off	Brake may be improperly adjusted or broken.	Check brake components. Contact Service for replacement parts or adjust instructions.
	Motor operator does not shut off at full OPEN or at full CLOSE position	Limits may need adjustment.	Refer to the operator owner's manual to readjust limits.
		Sprocket on limit shaft may be slipping or limit drive chain may be broken.	Ensure sprocket key is correctly installed and set screws are tightened. Contact Service for replacement chain if broken.
Limit switch may be defective.		Contact Service.	
Limit Switches	Limit switch does not hold setting	Drive chain may be too loose, allowing the chain to jump sprocket teeth.	Adjust chain to proper tension. Contact Service for additional information.
		Limit nut retainer not engaging slots in limit nuts.	Be sure retainer is securely engaged in slots of both limit nuts.
		Limit nuts binding on screw threads, allowing them to jump position on retainer.	Lube screw thread. Check that limit nuts turn freely.

▪ **Sealant application for NFPA 105 / UL 1784 compliance:**

Note: Read this sheet before installing unit.

- Assembly must be properly sealed with caulking and brush gasketing must be installed for unit to function in accordance with the performance criteria of NFPA 105.
- A multi-purpose sealant such as Dow Corning RTV silicone sealant #732 or equal must be applied to all surfaces of the unit which come into contact with the door opening and to all mating surfaces of the door assembly where air leakage is a possibility. This is especially important between the mating pieces of the guide assembly and between the brush seals and the guide.
- This material must be field applied according to the manufacturer's recommendations. It is best to drill or machine all parts and pre-fit them prior to applying the sealant material. This process will ensure the neatest job possible and help to determine the amount of sealing compound which needs to be applied. Application of only a very small amount of material is required to seal closely mating surfaces. The use of too much sealant will cause oozing when fasteners are tightened down making it necessary to clean off excess after material has cured.
- Refer to the "**Guides**" and "**Hood, Fascia, and Covers – Lintel Brush**" sections in this manual for instructions on installing brushes and applying the silicone sealing compound.