

Clopay® Canyon Ridge™ Collection Limited Warranty

We will repair or replace (at our option) any garage door section or hardware that is defective in material or workmanship pursuant to the terms of this limited warranty. This warranty extends to and benefits only the original purchaser of the garage door. This warranty does not apply to commercial, industrial or any other non-residential installation.

We will provide, at no cost to you, sections/section components, hardware springs/spring components or windows to repair or replace defective sections, hardware, springs/spring components or windows. All labor costs associated with the removal and reinstallation of any repaired section/section components, hardware or spring/spring components and the installation of replacement sections/section components, hardware, spring/spring components or windows will be your responsibility. We reserve the right to inspect and/or verify any claimed defect.

The applicable limited warranty periods are as follows:

Model #	Clopay Applied Finishing System	Insulated Windows	Hardware/ Torsion Springs/ Cladding & Overlay Delamination	Extension Springs
CAN111/112/113/121/122/123/131 CAN132/133/134/135/136/137/138 CAN211/212/213/221/222/223/231 CAN232/233/234/235/236/237/238	5 yrs.	10 yrs.	5 yrs.	3 yrs.

Terms and limitations of the limited warranty are further detailed below:

Finishing System Limited Warranty

Clopay warrants the sections of the Models listed above against factory applied paint finish cracking, checking or peeling (losing adhesion) as follows: (a) in residential single family installations for the years designated above from the date of installation to the original purchaser; (b) in all other residential installations (including installations on facilities owned in common by condominium associations or similar organizations), for five (5) years from date of installation to the original purchaser, pursuant to the terms of this limited warranty. Finishing System warranty does not apply to non-Clopay finished doors.

Hardware/Spring & Spring Component/Sections/Section Components Limited Warranty

We will repair or replace (at our option) any garage door hardware, section/section components, spring and/or spring component that is defective in material or workmanship for the term defined in the chart above, pursuant to the terms of this limited warranty. In addition, we will repair or replace (at our option) any garage door section/section component that is defective in material or workmanship, including, but not limited to, delamination of the composite cladding and overlays from the steel skin and/or delamination of the overlay from the steel. The overlay is warranted against excessive discoloration under the terms of this warranty.

Insulated Windows – 10 Year Limited Warranty

Insulated glass is warranted for a period of ten (10) years for material obstruction of vision resulting from film formation or dust or moisture collection between the interior surface of the insulating glass window. No warranty is available for clear glass.

WE WILL NOT PAY FOR ANY DAMAGES, INCLUDING INCIDENTAL OR CONSEQUENTIAL DAMAGES, CAUSED BY OR RESULTING FROM DEFECTIVE GARAGE DOOR SECTIONS OR HARDWARE. Some states do not allow the exclusion of incidental or consequential damages, so the above limitation may not apply to you.

Our warranty shall not extend to or cover deterioration due to damage or rust to the garage door caused by fire, an act of God, other accident or casualty, vandalism, radiation, harmful fumes or foreign substances in the atmosphere (including salt water spray), animal wastes, or occurring as a result of any physical damage or the failure of paint that is not applied per the manufacturer's specifications after the garage door left our factory, or failure to follow all installation, maintenance, and painting instructions. Nor shall our warranty extend to or cover any damages due to normal wear and tear, or claims with respect to any products that in any way or degree have been altered, processed, misused or improperly handled or installed.

If your garage door does not conform to this warranty, notify us in writing at the following address promptly after discovery of the defect. Clopay Building Products, Attn: Consumer Services Dept., 1400 W Market Street, Troy, Ohio 45373. Additional copies of our installation and maintenance instructions may be obtained by calling 1-800-225-6729.

WE MAKE NO OTHER WARRANTIES, REPRESENTATIONS, OR COVENANTS, EXPRESS OR IMPLIED, WITH RESPECT TO THIS PRODUCT, INCLUDING BUT NOT LIMITED TO WARRANTIES, REPRESENTATIONS, OR COVENANTS AS TO WORKMANSHIP, DESIGN, CAPACITY, QUALITY, CONDITION, MERCHANTABILITY, OR FITNESS FOR ANY PURPOSE OF THE PRODUCT, EXCEPT FOR ANY "IMPLIED WARRANTY" AS THAT TERM IS DEFINED IN THE MAGNUSON-MOSS WARRANTY-FEDERAL TRADE COMMISSION IMPROVEMENT ACT, SUCH IMPLIED WARRANTIES TO BE LIMITED IN DURATION TO A PERIOD OF ONE YEAR FROM THE DATE OF PURCHASE.

This warranty gives you specific legal rights, and you may also have other rights that vary from state to state.



© Clopay Building Products Company, Inc.
A Griffon Company, Inc. 2009



SUPPLEMENTAL INSTALLATION INSTRUCTIONS (For Use with the Insulated Steel Residential Garage Door Instruction Manual)

This is a supplement to the **Insulated Steel Residential Garage Door Instructions** (referred to as the MANUAL). It covers information unique to Canyon Ridge doors. For all other information and safety warnings concerning your Canyon Ridge garage door, see the MANUAL. Read the information in both manuals before beginning installation.

These instructions will cover the following areas where Canyon Ridge door installation differs from standard insulated steel door installation:

1. Finishing
2. Section Stacking
3. Strut Requirements
4. Operator Reinforcement and Attachment
5. Window Glass and Grille Removal
6. Lift Handle Installation
7. Flag Bracket
8. Warranty Information

Finishing

You can change the appearance (color) of your door or perform periodic maintenance and re-finishing by following the instructions below.

The finish on your door should be inspected for discoloration and coating delamination every 12 months and more frequently if exposed to direct sunlight or harsh environmental conditions. The door should be re-coated with a layer of exterior grade, UV resistant, clear protective topcoat every 5 years for maximum longevity. We recommend Minwax® Clear-Shield™ or Minwax® Helmsman® Spar Urethane.

Finish: We recommend a Minwax® gel stain or high quality exterior-grade latex paint. Gel stains tend to be more vivid than paints in final appearance; however exterior-grade latex paints tend to last longer.

Surface Preparation: Before painting your door, the overlay and cladding surfaces must be suitably prepared and cleaned.

Cleaning: Prior to painting, clean surface with mild store bought paint surface preparation cleaner. A final wipe and rinse with clean water and sponge should be done to remove any loose material. Change water often to ensure clean rinse and allow to dry. Pre test your paint on a small area. If the paint shows signs of poor adherence, there may be a problem with the paint or the surface preparation. DO NOT PROCEED! A new paint or further preparation of the surface needed.

Composite Wood Repair: Should your door's composite wood overlay or cladding become damaged, fill any gaps or voids in the composite surface with a paintable wood putty or urethane caulk. Let dry before painting.

Since all paints are not created equal, the following test needs to be performed: paint should be applied on a small area of the door (following the instructions on the paint container), allowed to dry, and evaluated prior to painting the entire door. Paint defects to look for are blistering and peeling. An additional test is to apply a strip of masking tape over the painted area and peel back, checking to see that the paint adheres to the door and not to the tape. After satisfactorily testing paint, follow the directions on the container and apply to the door. Be sure to allow adequate drying time should you wish to apply a second coat.

NOTE: Do not apply paint when door surface temperature is different from manufacturer's suggested temperature range for application.

Finishing your door with top coat of Gel Stain

To bring out light and dark highlights of the composite texture, there are two coats needed (two different colors), a lighter base coat of exterior-grade latex paint and a darker top coat of gel stain. Follow the manufacturer's instructions for surface preparation and stain application.

Step 1: Brush the lighter base coat of exterior grade latex paint completely into the composite texture for full coverage. Allow to dry overnight.

Step 2: Brush the darker top coat gel stain onto the door thoroughly, however, BEFORE THE GEL STAIN DRIES, using a sponge or cloth rag, wipe off a little or a lot of the stain (depending on your preference) to reveal areas of the base coat and use paint brush to even out coat. Allow to dry overnight.

Step 3: Apply a layer of exterior-grade, UV resistant, clear protective topcoat. Minwax® Clear Shield™ or Minwax® Helmsman® Spar Urethane would meet this requirement. Allow to dry.

Finishing your door with a top coat of Exterior-Grade Latex Paint

To bring out light and dark highlights of the composite texture, there are two coats of exterior-grade latex paint needed (two different colors), a lighter base coat and a darker top coat. Follow the manufacturer's instructions for surface preparation and stain application.

Step 1: Brush the lighter base coat paint completely into the composite texture for full coverage. Allow to dry overnight.

Step 2: Brush the darker top coat paint onto the door, however, BEFORE THE TOP COAT DRIES, using a sponge or cloth rag, wipe off a little or a lot of the top coat (depending on your preference) to reveal areas of the base coat and use brush to even coat out. Allow to dry overnight.

Stacking of Canyon Ridge Door Sections

Since Canyon Ridge doors are custom assembled one door at a time, it is important that matching sections stay together and that the sections are stacked in the correct order. Canyon Ridge door sections are labeled on the inside upper left hand corner of the section (See Figure 1). All sections for each Canyon Ridge door should have the same four digit identification number, and sections should be stacked in sequence, with #01 being the bottom section, the next section is #02, etc. Place the sections in this order until all sections are installed. Also there is an Alignment Label across section joints. To ensure proper alignment of the door, this label must line up between joining sections.

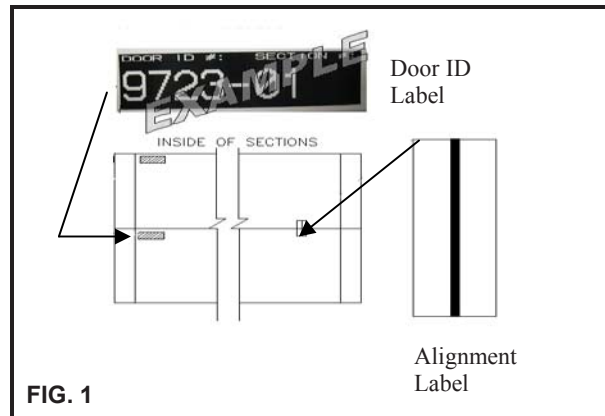

FIG. 1

Strut Requirements

The table below shows the strut requirements for Canyon Ridge doors.

Door Width	Strut Requirement	
	2-1/2" Thick End Stile	3" Thick End Stile
Up to 9'	None	None
10', 12'	(1) 2-1/4" strut per door	(1) 2-1/4" strut per door
15', 16'	(1) 2-1/4" strut per section*	(1) 2-1/4" strut per door
18'	(1) 3" strut per section*	(1) 2-1/4" strut per section*
20'	N/A	(1) 3" strut per section*

* Note: Window Lite section on double car doors may be packaged with two struts attached. Remove strut from bottom of window section and place on top of section #3.

Reinforcing the Top Section for Opener Attachment

To avoid damage to your door, you must reinforce the top section of the door in order to provide a mounting point for the opener to be attached. Failure to reinforce the door as illustrated will void your Clopay Warranty.

Attachment of Operator Reinforcement Bracket to Door: Figures 2 through 4 show the installation of the operator reinforcement bracket. Each illustration corresponds to a specific door width. At locations where the bracket is attached to the hinge, the hinge screws must be removed, the bracket installed, and the hinge screws then replaced.

For opener arm attachment instructions refer to the MANUAL.

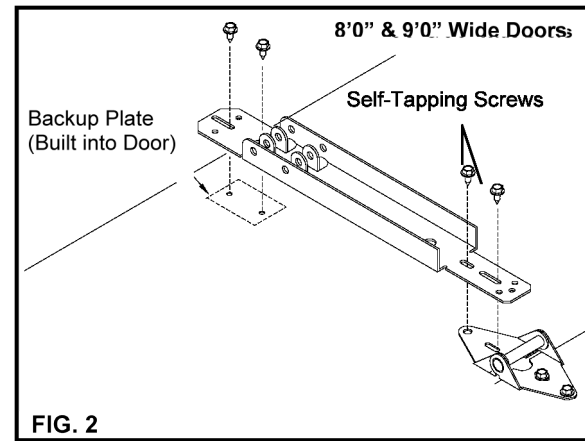

FIG. 2

Materials required:
(1) operator reinforcement bracket
(2) sheet metal screws

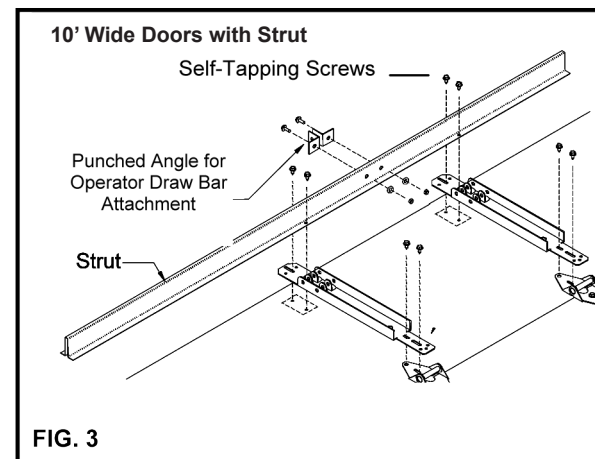

FIG. 3

Materials required:
(2) operator reinforcement brackets
(2) 2" pieces of 1/4" x 1/4" punched angle,
(2) 1/4" x 1" bolts,
(2) 1/4" lock washers,
(2) 1/4" nuts,
(4) 1/4" x 3/4" self-tapping screws

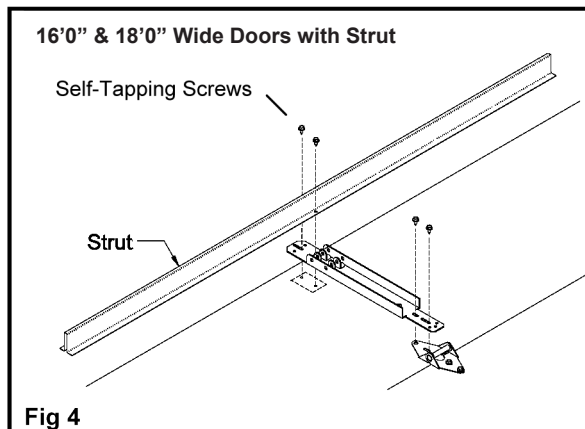

Fig 4

Materials required:
(1) operator reinforcement bracket
(2) 1/4" x 3/4" self-tapping screws

Glass Replacement / Window Grille Removal



To avoid injury, use extreme caution in handling glass window pane. When the frame is removed, the exposed steel edge of the door may be sharp. Avoid contact with the sharp edges.

If your door is equipped with windows and the glass or window grilles need removed or replaced, follow the steps below.

- 1) Remove the screws from the inside window frame.
- 2) Pull the inside frame out of the door.
- 3) Carefully remove the glass and then the window grille.
- 4) Insert the new window grille (if needed) and the new glass.
- 5) Reinsert the screws into the inside frame, trapping the glass.

Installing Lift Handles

Step 1: Center the horizontal ornamental lift handle horizontally on the outside of the bottom door section. Using the handle as a template, mark the holes to be drilled. The holes must be located exactly 2" from the bottom of the section (See Fig. 5).

Step 2: Drill two 1/4" holes straight through the door at the marks.

Step 3: From the outside, enlarge the two 1/4" holes using a 3/8" drill, being careful not to drill through the inside skin of the door. Remove any excess foam from the 3/8" holes.

Step 4: Insert the appropriate 3/8" diameter spacer(s) into each hole from the outside of the door.

Door Thickness	Spacers Required for each hole
2-1/2"	(2) 1-3/16"
3"	(1) 1-13/16" + (1) 1-3/16"

Caution: Failure to install spacers may result in damage to the door.

Step 5: Attach the black ornamental handle (outside) and the steel roll grip handle (inside) to the door using two 1/4" black painted hex head bolts, and two 1/4" hex nuts (See Fig. 6).

Step 6: Take the two vertical ornamental handles and position on the 2nd section. Using the handles as a template, mark the holes to be drilled. With the sections stacked, the lower hole on each vertical handle must lie between 20" and 30" vertically from the holes on the bottom handle. The holes on each vertical handle should be centered 5-1/2" horizontally from each other. The holes on both vertical handles should line exactly with the holes on the bottom horizontal handle. No hole may be closer than 2" to the top or bottom of the section (See Fig. 5).

Step 7: Drill four 1/4" holes straight through the door at the marks.

Step 8: From the outside, enlarge the four 1/4" holes using a 3/8" drill, being careful not to drill through the inside skin of the door. Remove any excess foam from the 3/8" holes.

Step 9: Insert a 3/8" diameter spacer into each hole from the outside of the door. **Caution: Failure to install spacers may result in damage to the door.**

Step 10: Attach each vertical ornamental handle (outside) and one steel horizontal roll grip handle (inside) to the door using two 1/4" black painted hex head bolts, and two 1/4" hex nuts. Use a set of hex head bolts and hex nuts to fasten the vertical handles to the door through the remaining holes. The inside handle may be matched with either set of holes so long as it is no closer than 4" to the top or bottom of the section (See Fig. 7).

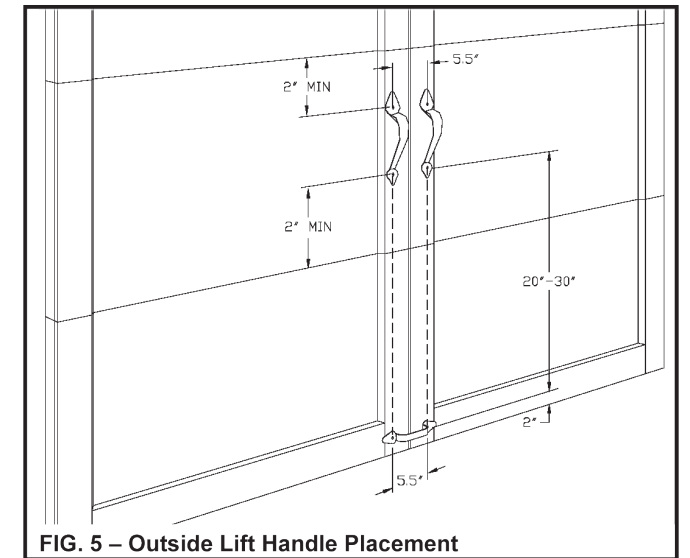

FIG. 5 – Outside Lift Handle Placement

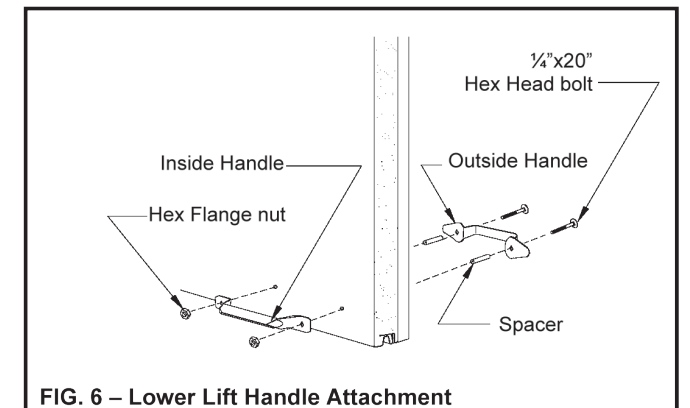

FIG. 6 – Lower Lift Handle Attachment

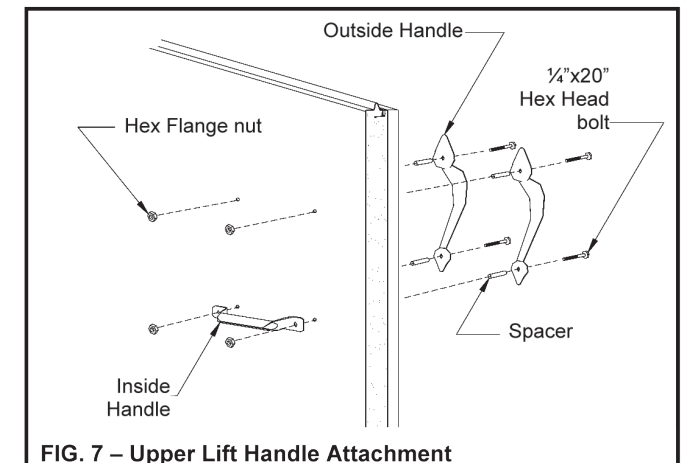

FIG. 7 – Upper Lift Handle Attachment

Flag Bracket

Because of the overall door thickness of most Canyon Ridge models, a commercial style flag bracket is used to splice the vertical and horizontal tracks together. An illustration of this bracket is shown in Fig. 8.

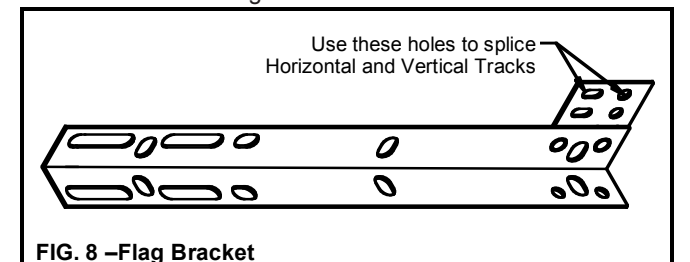

FIG. 8 –Flag Bracket