

MODEL 3150, 210

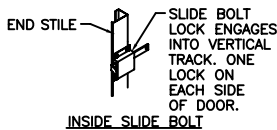
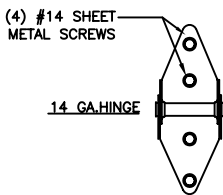
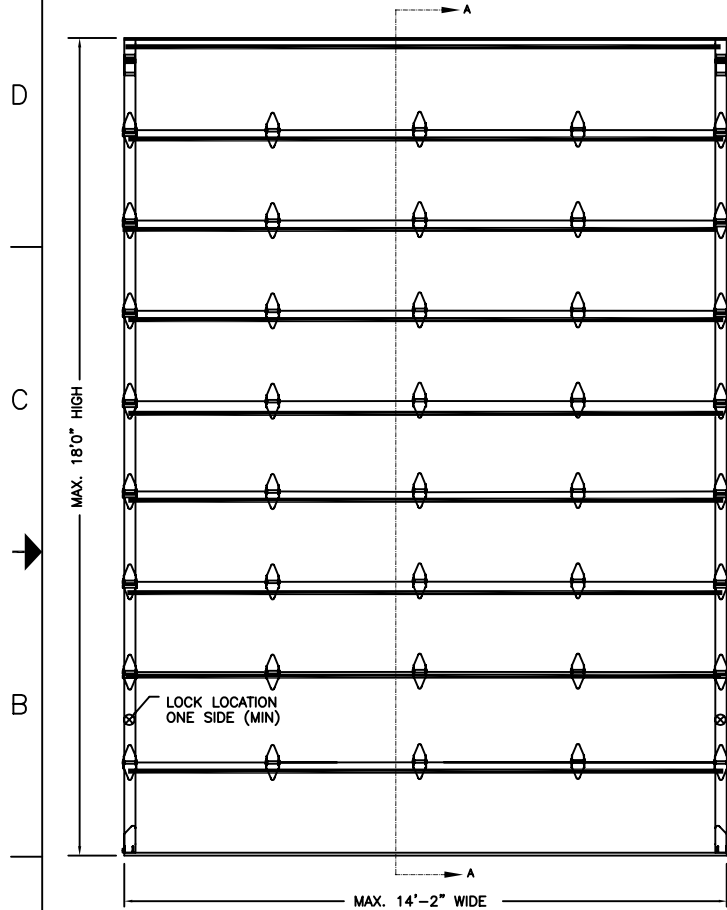

DESIGN ENGINEER: MARK WESTERFIELD, P.E.
 FLORIDA P.E. #48495
 DESIGN LOADS: +13.5 PSF & -13.5 PSF
 TEST LOADS: +20 PSF & -20 PSF

THE SUPPORTING STRUCTURAL ELEMENTS ARE TO BE DESIGNED BY THE BUILDING ARCHITECT OR ENGINEER OF RECORD FOR THE LOADS SHOWN ON THIS DRAWING.

REVISIONS						
REV. NO.	ZONE	DATE	ECN NO.	APPVD:	DESCRIPTION	
00	-	11/03/03	ER1037	SH	INITIAL RELEASE	
01	-	1/10/07	-	SH	DRAWING_CORRECTIONS	

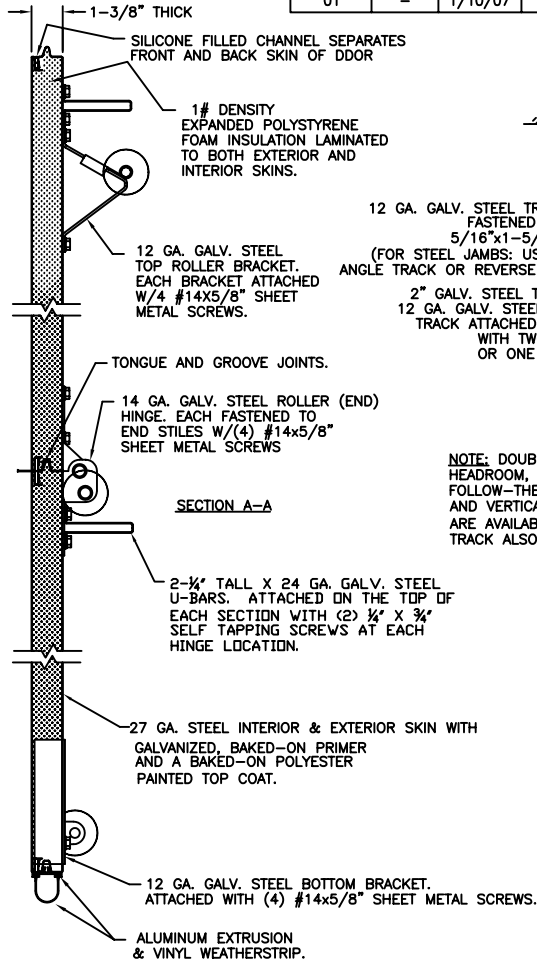

PREPARATION OF JAMBS BY OTHERS.

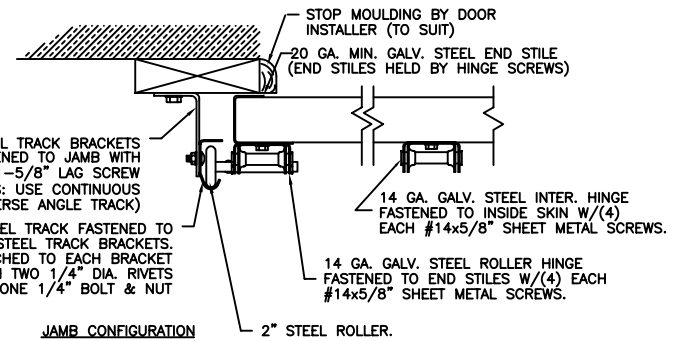

NOTE: DOUBLE TRACK LOW HEADROOM, HI-LIFT TRACK, FOLLOW-THE-ROOF TRACK, AND VERTICAL LIFT TRACK ARE AVAILABLE OPTIONS. 3" TRACK ALSO AVAILABLE.

HORIZONTAL TRACK SUPPORT BY DOOR INSTALLER (TO SUIT)

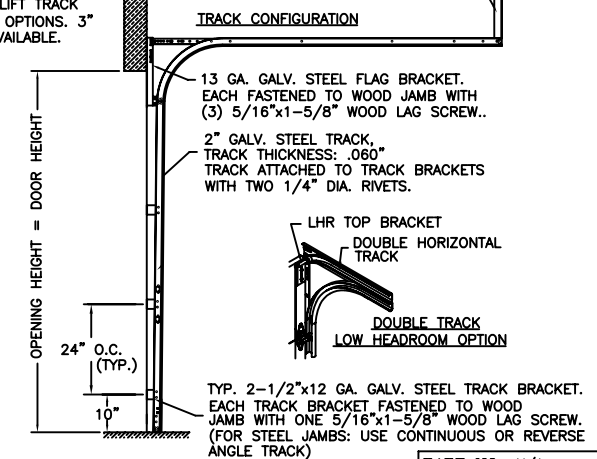

NOTICE: Confidential/Proprietary Information of CLOPAY BUILDING PRODUCTS CO. is contained herein and may not be disclosed, used, duplicated, made available, or distributed without the prior consent. Failure to observe this notice may result in liability for any damages and losses resulting therefrom.

Unless Stated Otherwise TOLERANCES are
 .0 = ±.031
 .00 = ±.015
 .000 = ±.005
 .0000 = ±.001
 Degrees = ±1/2°
 Third Angle Projection

Clopay
 Building Products Company

8585 Duke Boulevard
 Mason, OH 45040 USA
 Tel. No. 513-770-4800
 Fax No. 513-770-4853

DESCRIPTION: MODEL 3150W1 14' WIDE

DRAWN BY: RJK DATE: 8/20/03

CHECKED BY: SH DATE: 08/28/03

DWG. NO.: 102966

PART NO.: N/A	
WINDLOAD RATING W1	
SCALE: NONE	DWG. B
SHEET 1 OF 1	SIZE B
REV. NO. 00	