

MODEL 3150, 210

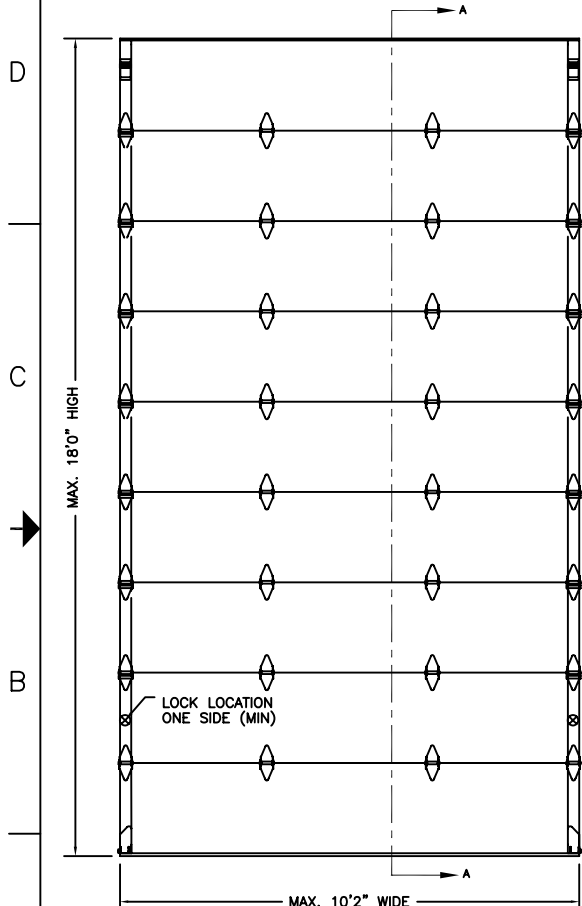

(4) #14 SHEET METAL SCREWS

INSIDE ELEVATION

14 GA. HINGE

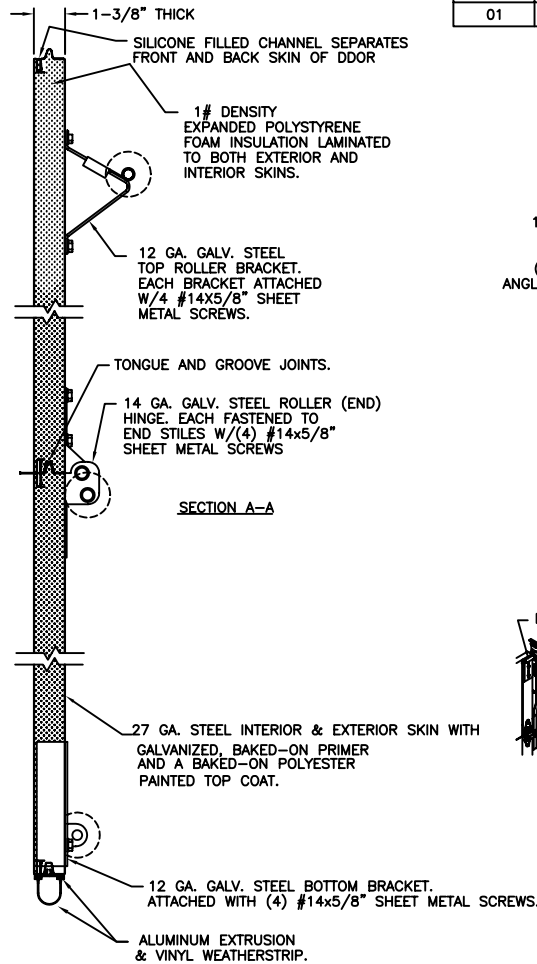
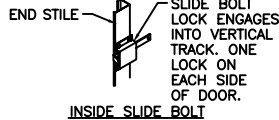
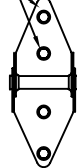

DESIGN ENGINEER: MARK WESTERFIELD, P.E.
FLORIDA P.E. #48495
DESIGN LOADS: +13.5 PSF & -13.5 PSF
TEST LOADS: +20 PSF & -20 PSF

THE SUPPORTING STRUCTURAL ELEMENTS ARE TO BE DESIGNED BY THE BUILDING ARCHITECT OR ENGINEER OF RECORD FOR THE LOADS SHOWN ON THIS DRAWING.

REVISIONS						
REV. NO.	ZONE:	DATE:	ECN NO.	APPVD:	DESCRIPTION	
00	-	11/03/03	ER1037	SH	INITIAL RELEASE	
01	-	1/09/07	-	SH	DRAWING_CORRECTIONS	

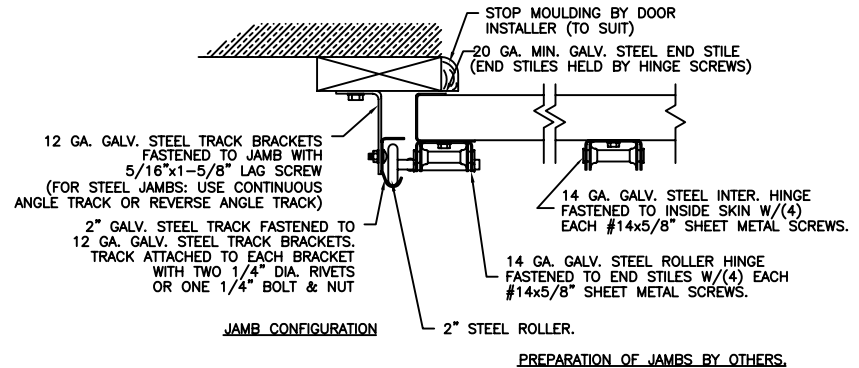

NOTE: DOUBLE TRACK LOW HEADROOM, HI-LIFT TRACK, FOLLOW-THE-ROOF TRACK, AND VERTICAL LIFT TRACK ARE AVAILABLE OPTIONS. 3" TRACK ALSO AVAILABLE.

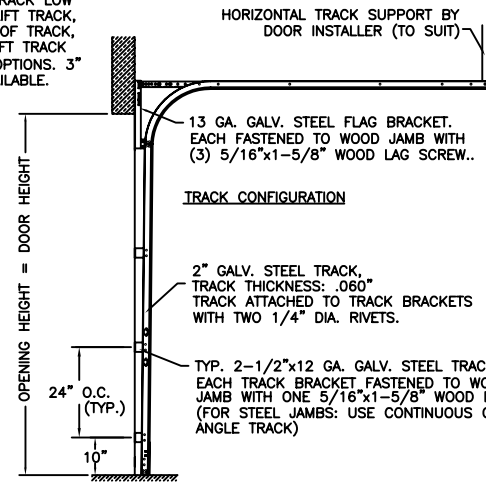
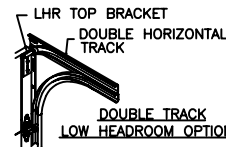

NOTICE: Confidential/Proprietary Information of CLOPAY BUILDING PRODUCTS CO. is contained herein and may not be disclosed, used, duplicated, made available, or distributed without the prior consent. Failure to observe this notice may result in liability for any damages and losses resulting therefrom.

Unless Stated Otherwise TOLERANCES are
.0 = ±.031
.00 = ±.015
.000 = ±.005
.0000 = ±.001
Degrees = ±1/2°
Unless Stated Otherwise DIMENSIONS ARE IN INCHES.

Clopay
Building Products Company
8585 Duke Boulevard
Mason, OH 45040 USA
Tel. No. 513-770-4800
Fax No. 513-770-4853

DESCRIPTION: MODEL 3150W1 10' WIDE

DRAWN BY: RJK DATE: 8/19/03 SCALE: NONE DWG. B

CHECKED BY: SH DATE: 08/28/03 SHEET 1 OF 1 SIZE B

DWG. NO.: 102964 REV. NO. 01

PART NO.: N/A			
DWG. NO.: 102964	REV. NO. 01		