

4

3

2

1

MODELS B178/251S, B278/251L, 55S, 55L, S51S, S51L (25 GA STEEL SKIN WITH EMBOSSED PANELS)  
 MODELS B378/251F, S51F (25 GA STEEL SKIN WITH FLUSH PANELS)

REVISIONS					
REV. NO.	ZONE:	DATE:	ECN NO.	APPVD:	DESCRIPTION
00	-	11/03/03	ER1037	SH	INITIAL RELEASE

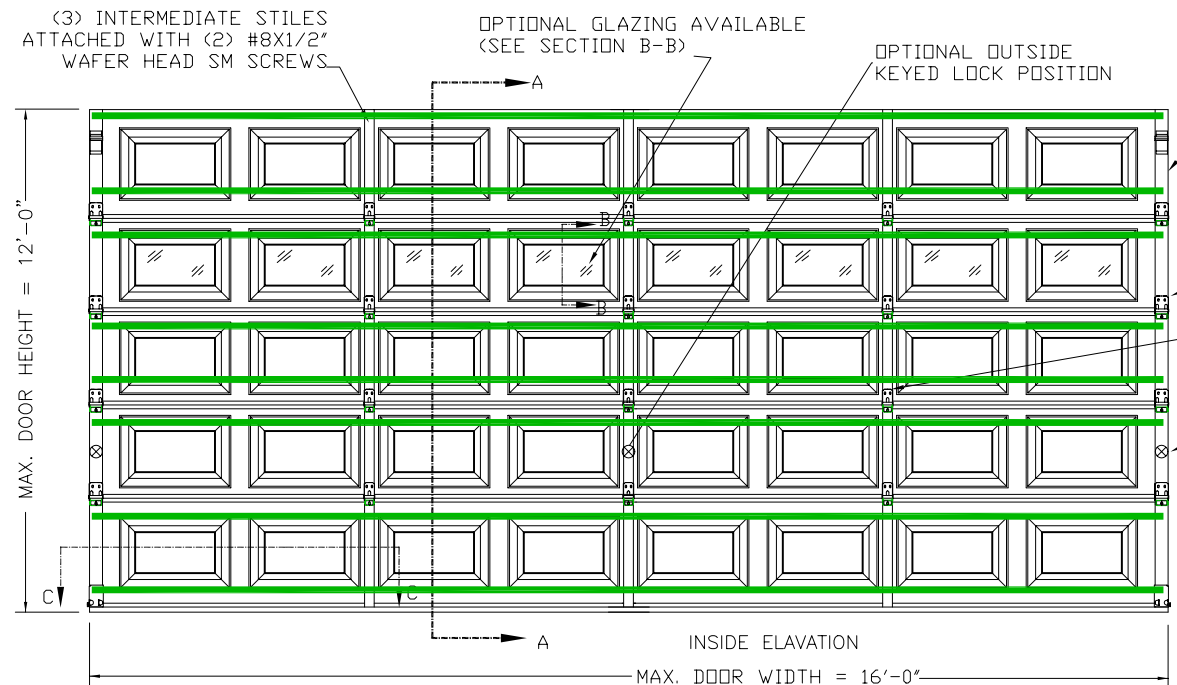

DOOR HEIGHT	NUMBER OF SECTIONS*
6'0" TO 7'0"	4
7'6" TO 8'9"	5
9'0" TO 10'6"	6
10'9" TO 12'0"	7

(SHOWN)  
 \* - SECTIONS ARE EITHER 18" OR 21" HIGH

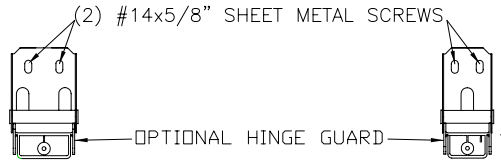
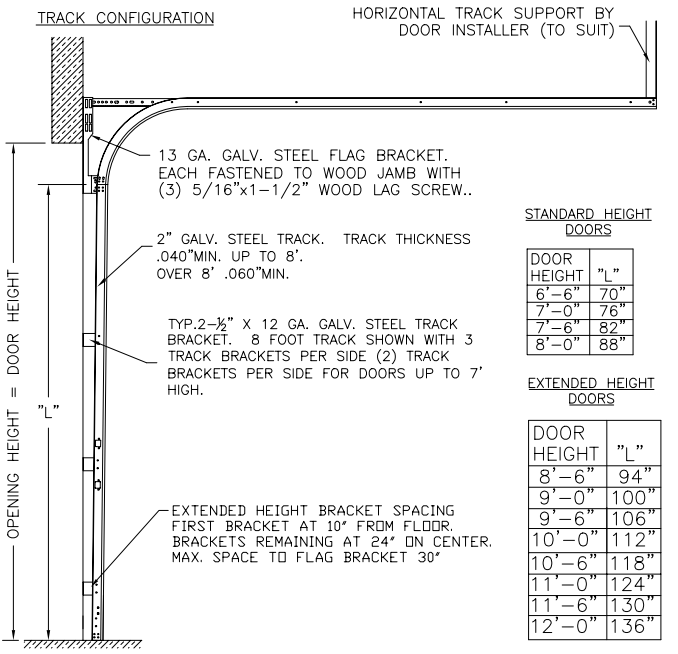
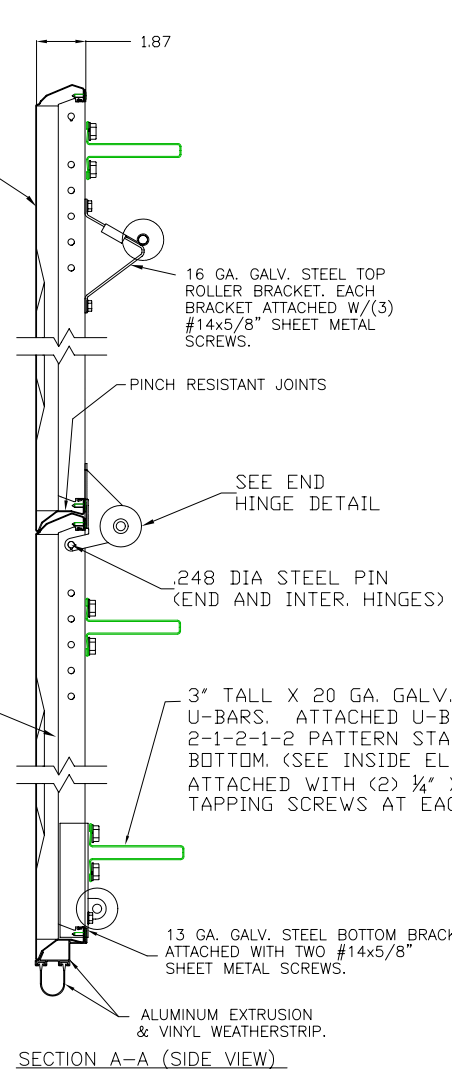

18 GA. END HINGES DETAIL

18 GA. INTERMEDIATE HINGE DETAIL

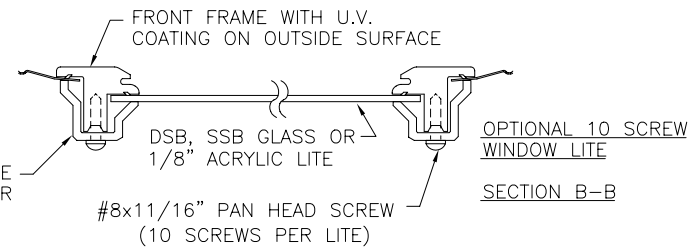

MOLDED INSIDE LITE RETAINER

OPTIONAL 10 SCREW WINDOW LITE SECTION B-B

VERTICAL JAMB ATTACHMENT (WOOD FRAME BUILDINGS):  
 OPTION ONE: 3/8" x 3" LAG SCREWS ON 24" CENTERS. 1" O.D. MIN. WASHER REQUIRED. LAG SCREWS MAY BE COUNTERSUNK (NOT REQUIRED) TO PROVIDE A FLUSH MOUNTING SURFACE.  
 OPTION TWO: 16D x 3-1/2" COMMON WIRE NAILS ON 7" CENTERS. (HORIZONTAL JAMBS DO NOT TRANSFER LOAD.)

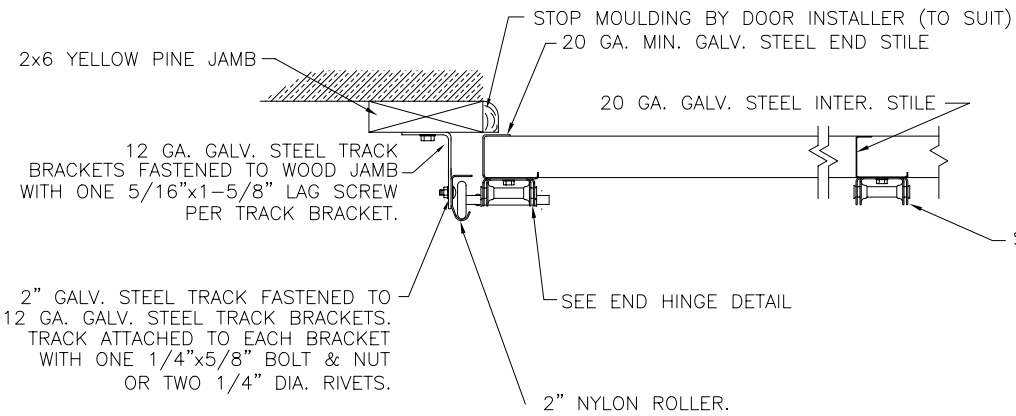

PREPARATION OF JAMBS BY OTHERS.

JAMB CONFIGURATION SECTION C-C

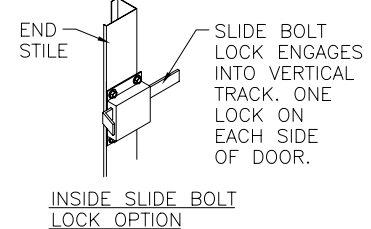

INSIDE SLIDE BOLT LOCK OPTION

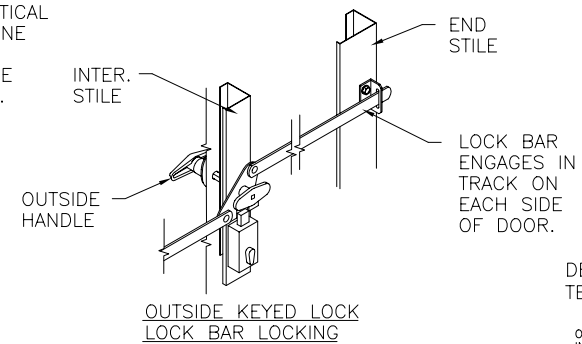

OUTSIDE KEYED LOCK LOCK BAR LOCKING

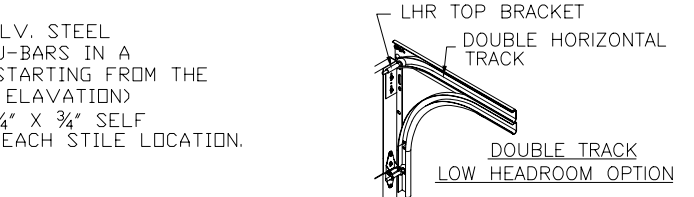

LHR TOP BRACKET DOUBLE HORIZONTAL TRACK DOUBLE TRACK LOW HEADROOM OPTION

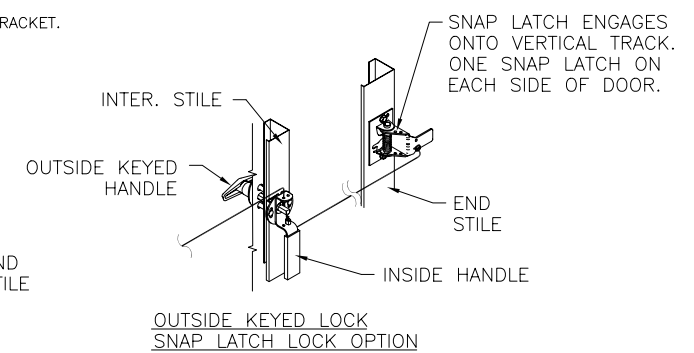

DESIGN ENGINEER: MARK WESTERFIELD, P.E.  
 FLORIDA P.E. #48495, N.C. P.E. 23832, TEXAS P.E. 91513

DESIGN LOADS: +12.5 P.S.F. & -14 P.S.F.  
 TEST LOADS: +19 P.S.F. & -21 P.S.F.

ORIGINAL DRAWINGS ARE SIGNED IN BLUE INK WITH A RAISED SEAL (EMBOSS).

PART NO.:

NOTE 2: THE DESIGN OF THE SUPPORTING STRUCTURAL ELEMENTS SHALL BE THE RESPONSIBILITY OF THE PROFESSIONAL OF RECORD FOR THE BUILDING OR STRUCTURE AND IN ACCORDANCE WITH CURRENT BUILDING CODES FOR THE LOADS LISTED ON THIS DRAWING.

NOTICE: Confidential/Proprietary information of CLOPAY BUILDING PRODUCTS CO. is contained herein and may not be disclosed, used, duplicated, made available, or distributed without its prior consent. Failure to observe this notice may result in liability for any damages and losses resulting therefrom.

Unless Stated Otherwise TOLERANCES are  
 .0 = ±.031  
 .00 = ±.015  
 .000 = ±.005  
 .0000 = ±.001  
 Degrees = ±1/2'



Third Angle Projection

**Glopay** Building Products Company  
 8585 Duke Boulevard  
 Mason, OH 45040 USA  
 Tel. No. 513-770-4800  
 Fax No. 513-770-4853

DESCRIPTION: 251SW1 DOUBLE CAR

DRAWN BY: RJK	DATE: 8/26/03	SCALE: NTS	DWG. SIZE B
CHECKED BY: -	DATE: -	SHEET 1 OF 1	
DWG. NO.: 102937	REV. NO. 00		

4

3

2

1