



SUPPLEMENTAL INSTALLATION INSTRUCTIONS

(For Use with the Insulated Steel Residential Garage Door Instruction Manual)

This is a supplement to the Insulated Steel Residential Garage Door Instructions (referred to as the MANUAL). It covers information unique to Coachman Collection Doors. For all other information and safety warnings concerning your Coachman Collection garage door, see the MANUAL. Read the information in both manuals before beginning installation.

These instructions will cover the following areas where Coachman door installation differs from standard insulated steel door installation:

1. Cleaning and Maintenance
2. Painting
3. Section Stacking
4. Strut Requirements
5. Operator Reinforcement and Attachment
6. Lift Handle Installation
7. Flag Bracket ("CP" Models only)
8. Warranty Information

Cleaning and Maintenance

In order to prevent damage caused by foreign matter adhering to the door, the door should be cleaned at least twice per year. The door should be wiped down with a white cloth or rag using a mild household detergent and rinsed with clear water. Do not use colored rags as the dyes may cause discoloration of the door surface.

Special Instructions for Glue Removal: Some glue may accumulate on the door surface or the composite overlay surface during the manufacturing process. Glue can be removed by wiping the door surface with a rag saturated with Xylene (Xylol), available at most paint or hardware stores. Wiping should be done at moderate pressure and Xylene must not be allowed to sit on the door for an extended period of time. Damage to your door's paint system can occur if overexposed to this or other solvents.

Caution: Safety instructions on the solvent's container must be followed.

Painting

Surface Preparation: Before painting your door, both the steel and PVC surfaces must be suitably prepared and cleaned. Before cleaning the door, thoroughly scuff the entire exposed surface of the PVC overlays, window grilles, and window frames with medium sandpaper.

NOTE: Sanding could remove rust-inhibiting compounds from the steel portion of the door, therefore, sanding should be done only to the PVC overlays and to damaged areas where bare metal has been exposed (refer to the "Repair" section of these instructions).

The pre-painted surfaces can be cleaned of dirt, oils, chalk, and mildew with a diluted solution of trisodium phosphate. Trisodium phosphate is available over the counter at most stores under the name SOILAX, in many laundry detergents without fabric softener additives, and in some general purpose cleaners. Check the label for trisodium phosphate content. The

recommended concentration is 1/3 cup of powder to 1-1/2 to 2 gallons of water. After washing the door, always rinse well with clear water and allow to dry.

If the door has ever been waxed, the wax must be removed before painting (doors are not waxed during the manufacturing process). Wax can be removed by wiping the door with a rag saturated with Xylene. For proper use, see glue removal instructions in the Cleaning and Maintenance section to the left. After de-waxing the door, clean with trisodium phosphate as stated previously.

Repair: Should your door's paint finish become damaged, exposing the bare metal, it will become necessary to repair this area to prevent rust from forming. The damaged area should be lightly sanded with a medium to fine sandpaper making sure to remove all visible red and white rust. Wipe this area with a dry, clean rag. Coat the sanded area with a high quality, rust inhibiting, zinc enriched primer. This type of primer can be found at most paint or hardware stores, and should be labeled for covering bare and galvanized steel. Once the primer is applied, wait the time specified on the primer's instructions before you finish painting your door.

Paint: Your garage door can be painted with a high-quality 100% acrylic latex (flat, satin, or semi gloss) exterior grade paint. Do not use an oil-based paint, as it will not adhere properly to the surface of the door.

IMPORTANT: DO NOT PAINT DOOR DARK COLORS. Dark colors absorb radiant heat from the sun creating extremely high surface temperatures, which could cause distortion of the PVC overlay. Do NOT paint the PVC overlay with a paint that has a Light Reflective Value (LRV) of less than 56. The base door (steel) must NOT be painted a LRV of less than 38. Failure to follow these instructions will void the door's warranty. For more information call our Consumer Services Hotline at 1-800-225-6729 or visit <http://info.clopaydoor.com>.

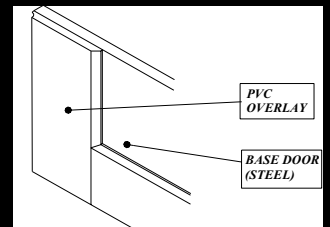

Since all paints are not created equal, the following test needs to be performed: paint should be applied on a small area of the door (following the instructions on the paint container), allowed to dry, and evaluated prior to painting the entire door. Paint defects to look for are blistering and peeling. An additional test is to apply a strip of masking tape over the painted area and peel back, checking to see that the paint adheres to the door and not to the tape. After satisfactorily testing a paint, follow the directions on the container and apply to the door. Be sure to allow adequate drying time should you wish to apply a second coat.

NOTE: Do not apply paint when door surface temperature is different from manufacturer's suggested temperature range for application.

Stacking of Coachman Door Sections

Since Coachman doors are custom assembled one door at a time, it is important that matching sections stay together and that the sections are stacked in the correct order. Coachman door sections are labeled on the inside upper left hand corner of the section (See Figure 1). All sections for each Coachman door should have the same four digit identification number, and sections should be stacked in sequence, with #01 being the bottom section, the next section is #02, etc. Place the sections in this order until all sections are installed. Also there is an Alignment Label across section joints. To ensure proper alignment of the door, this label must line up between joining sections.

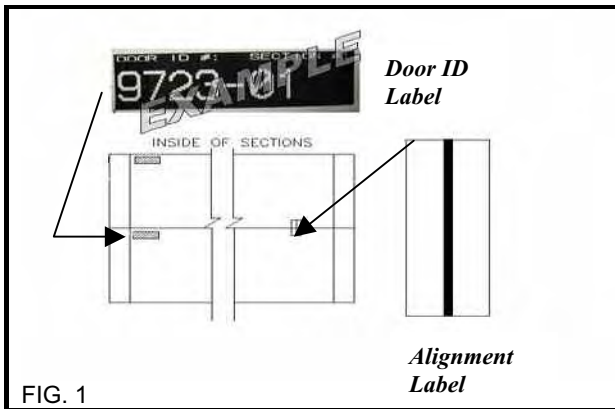

FIG. 1

Strut Requirements

The table below shows the strut requirements for Coachman doors.

Door Width	Strut Requirement	
	2" Thick End Stile ("C" Models)	2-5/8" Thick End Stile ("CP" Models)
Up to 9'	No Struts Required	No Struts Required
10', 12'	(1) 2-1/4" Strut on Top Section	(1) 2-1/4" Strut on Top Section
16'	(1) 2-1/4" Strut per Section*	(1) 2-1/4" Strut on Top Section
18'	(1) 3" Strut per Section*	(1) 2-1/4" Strut per Section*

* Note: Window Lite section on double car doors may be packaged with two struts attached. Remove strut from bottom of window section and place on top of section #3.

Reinforcing the Top Section for Opener Attachment

To avoid damage to your door, you must reinforce the top section of the door in order to provide a mounting point for the opener to be attached. Failure to reinforce the door as illustrated will void your Clopay Warranty.

Attachment of Operator Reinforcement Bracket to Door:

Figures 2 through 4 show the installation of the operator reinforcement bracket. Each illustration corresponds to a specific door width. At locations where the bracket is attached to the hinge, the hinge screws must be removed, the bracket installed, and the hinge screws then replaced.

For opener arm attachment instructions refer to the MANUAL.

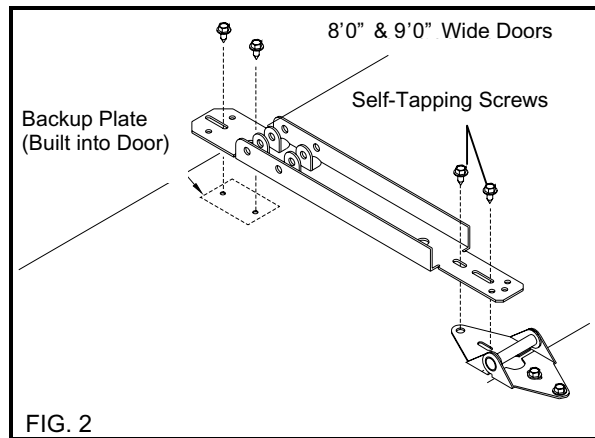

FIG. 2

Materials required:

- (1) operator reinforcement bracket
- (2) sheet metal screws

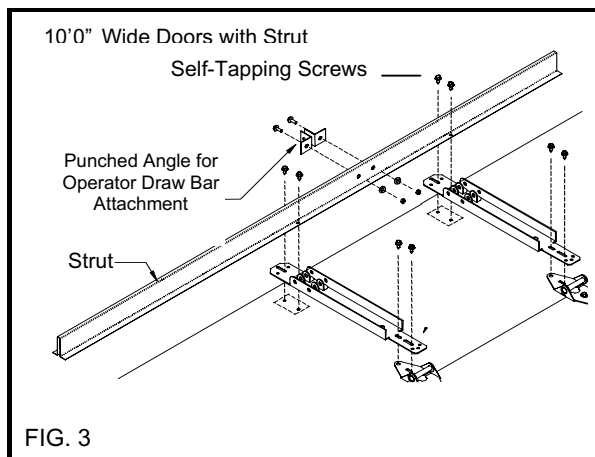

FIG. 3

Materials required:

- (2) operator reinforcement brackets
- (2) 2" pieces of 1 1/4" x 1 1/4" punched angle,
- (2) 1/4" x 1" bolts,
- (2) 1/4" lock washers,
- (2) 1/4" nuts,
- (4) 1/4" x 3/4" self-tapping screws

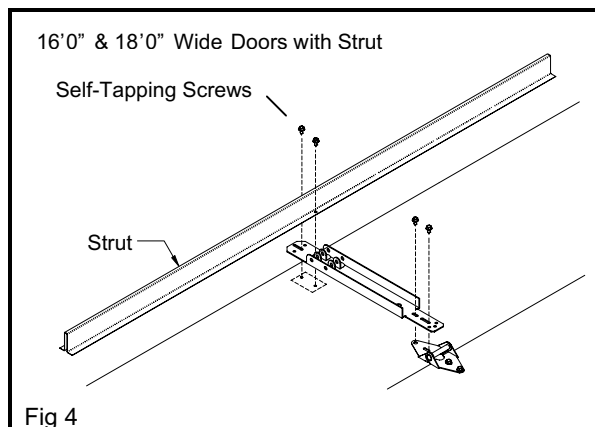

Fig 4

Materials required:

- (1) operator reinforcement bracket
- (2) 1/4" x 3/4" self-tapping screws

Installing Lift Handles

Step 1: Center the horizontal ornamental lift handle horizontally on the outside of the bottom door section. Using the handle as a template, mark the holes to be drilled. The holes must be located exactly 2" from the bottom of the section (See Fig. 5).

Step 2: Drill two 1/4" holes straight through the door at the marks.

Step 3: From the outside, enlarge the two 1/4" holes using a 3/8" drill, being careful not to drill through the inside skin of the door. Remove any excess foam from the 3/8" holes.

Step 4: Insert a 3/8" diameter spacer into each hole from the outside of the door. Caution: Failure to install spacers may result in damage to the door.

Step 5: Attach the black ornamental handle (outside) and the steel roll grip handle (inside) to the door using two 1/4" black painted hex head bolts, and two 1/4" hex nuts (See Fig. 6).

Step 6: Take the two vertical ornamental handles and position on the 2nd section. Using the handles as a template, mark the holes to be drilled. With the sections stacked, the lower hole on each vertical handle must lie between 20" and 30" vertically from the holes on the bottom handle. The holes on each vertical handle should be centered 5-1/2" horizontally from each other. The holes on both vertical handles should line exactly with the holes on the bottom horizontal handle. No hole may be closer than 2" to the top or bottom of the section (See Fig. 5).

Step 7: Drill four 1/4" holes straight through the door at the marks.

Step 8: From the outside, enlarge the four 1/4" holes using a 3/8" drill, being careful not to drill through the inside skin of the door. Remove any excess foam from the 3/8" holes.

Step 9: Insert a 3/8" diameter spacer into each hole from the outside of the door. Caution: Failure to install spacers may result in damage to the door.

Step 10: Attach each vertical ornamental handle (outside) and one steel horizontal roll grip handle (inside) to the door using two 1/4" black painted hex head bolts, and two 1/4" hex nuts. Use a set of hex head bolts and hex nuts to fasten the vertical handles to the door through the remaining holes. The inside handle may be matched with either set of holes so long as it is no closer than 4" to the top or bottom of the section (See Fig. 7).

Flag Bracket ("CP" Models Only)

Because of the overall door thickness of the "CP" models, a commercial style flag bracket is used to splice the vertical and horizontal tracks together. An illustration of this bracket is shown in Fig. 8.

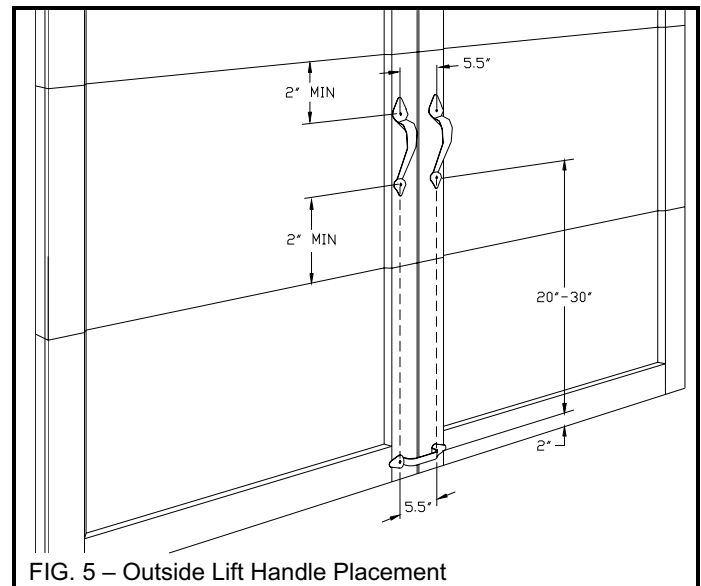

FIG. 5 – Outside Lift Handle Placement

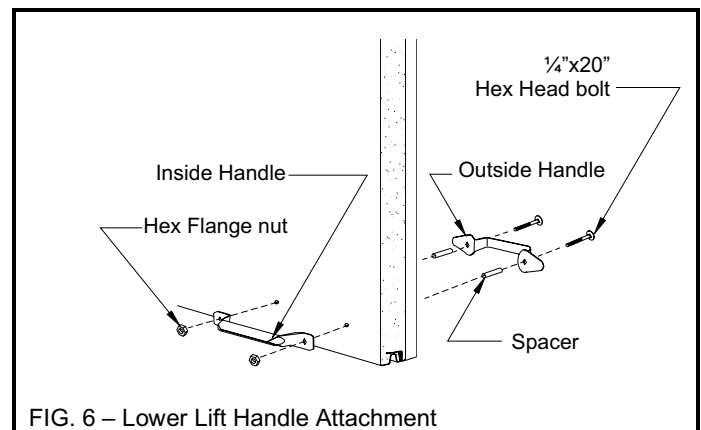

FIG. 6 – Lower Lift Handle Attachment

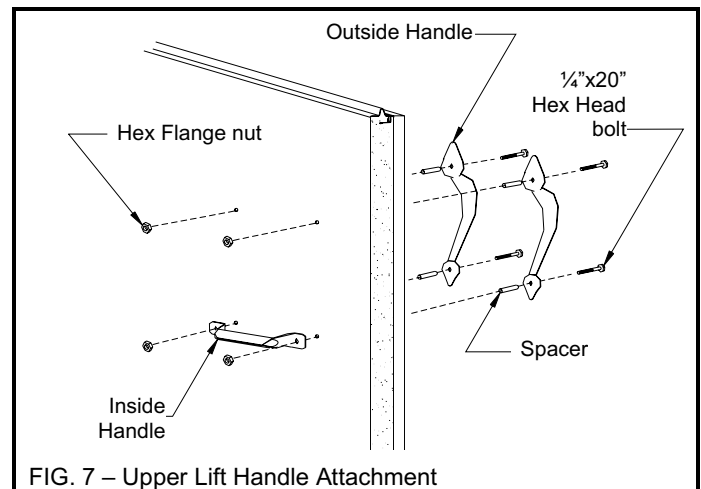

FIG. 7 – Upper Lift Handle Attachment

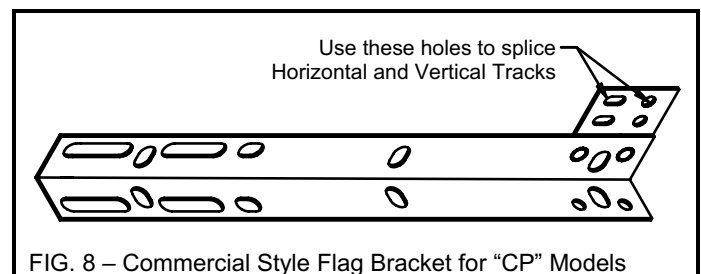

FIG. 8 – Commercial Style Flag Bracket for "CP" Models

Clipay® Coachman Collection Limited Warranty

We will repair or replace (at our option) any garage door section or hardware that is defective in material or workmanship pursuant to the terms of this limited warranty. This warranty extends to and benefits only the original purchaser of the garage door. This warranty does not apply to commercial, industrial or any other non-residential installation.

We will provide, at no cost to you, sections/section components, hardware springs/spring components or windows to repair or replace defective sections, hardware, springs/spring components or windows. All labor costs associated with the removal and reinstallation of any repaired section/section components, hardware or spring/spring components and the installation of replacement sections/section components, hardware, spring/spring components or windows will be your responsibility. We reserve the right to inspect and/or verify any claimed defect.

The applicable limited warranty periods are as follows:

Model #	Paint System	Windows / Overlay Discoloration	Hardware/ Torsion Springs/ Overlay Delamination	Extension Springs
C11, C12, C13, C21, C22, C23, C31, C32, C33, C34, C35 CP11, CP12, CP13, CP21, CP22, CP23, CP31, CP32, CP33, CP34, CP35	Limited Lifetime	10 yrs.	5 yrs.	3 yrs.

Terms and limitations of the limited warranty are further detailed below:

Paint System Limited Warranty

Clipay warrants the sections of the Models listed above against rust through due to the paint finish cracking, checking or peeling (losing adhesion) as follows: (a) in residential single family installations for the years designated above from the date of delivery to the original purchaser; (b) in all other residential installations (including installations on facilities owned in common by condominium associations or similar organizations), for ten (10) years from date of delivery to the original purchaser, pursuant to the terms of this limited warranty.

Hardware/Spring & Spring Component/Sections/Section Components Limited Warranty

We will repair or replace (at our option) any garage door hardware, section/section components, spring and/or spring component that is defective in material or workmanship for the term defined in the chart above, pursuant to the terms of this limited warranty. In addition, we will repair or replace (at our option) any garage door section/section component that is defective in material or workmanship, including, but not limited to, delamination of the polystyrene insulation from the steel skin and/or delamination of the overlay from the steel. The overlay is warranted against excessive discoloration under the terms of this warranty.

Decorative Windows – 10 Year Limited Warranty

Window frames are warranted for ten (10) years from date of purchase against manufacturing defects and excessive discoloration. This warranty does not cover any damage or loss caused by harmful chemical action, abrasive cleaners, or breakdowns due to climate extremes or environmental conditions. Insulated glass is warranted for a period of ten (10) years for material obstruction of vision resulting from film formation or dust or moisture collection between the interior surface of the insulating glass window. No warranty is available for clear glass.

WE WILL NOT PAY FOR ANY DAMAGES, INCLUDING INCIDENTAL OR CONSEQUENTIAL DAMAGES, CAUSED BY OR RESULTING FROM DEFECTIVE GARAGE DOOR SECTIONS OR HARDWARE. Some states do not allow the exclusion of incidental or consequential damages, so the above limitation may not apply to you.

Our warranty shall not extend to or cover deterioration due to damage or rust to the garage door caused by fire, an act of God, other accident or casualty, vandalism, radiation, harmful fumes or foreign substances in the atmosphere (including salt water spray), animal wastes, or occurring as a result of any physical damage or the failure of paint that is not applied per the manufacturer's specifications after the garage door left our factory, or failure to follow all installation, maintenance, and painting instructions. Nor shall our warranty extend to or cover any damages due to normal wear and tear, or claims with respect to any products that in any way or degree have been altered, processed, misused or improperly handled or installed.

If your garage door does not conform to this warranty, notify us in writing at the following address promptly after discovery of the defect. Clipay Building Products, Attn: Consumer Services Dept., 101 Miller Road, Russia, Ohio 45363. Additional copies of our installation and maintenance instructions may be obtained by calling 1-800-225-6729.

WE MAKE NO OTHER WARRANTIES, REPRESENTATIONS, OR COVENANTS, EXPRESS OR IMPLIED, WITH RESPECT TO THIS PRODUCT, INCLUDING BUT NOT LIMITED TO WARRANTIES, REPRESENTATIONS, OR COVENANTS AS TO WORKMANSHIP, DESIGN, CAPACITY, QUALITY, CONDITION, MERCHANTABILITY, OR FITNESS FOR ANY PURPOSE OF THE PRODUCT, EXCEPT FOR ANY "IMPLIED WARRANTY" AS THAT TERM IS DEFINED IN THE MAGNUSON-MOSS WARRANTY-FEDERAL TRADE COMMISSION IMPROVEMENT ACT, SUCH IMPLIED WARRANTIES TO BE LIMITED IN DURATION TO A PERIOD OF ONE YER FROM THE DATE OF PURCHASE.

This warranty gives you specific legal rights, and you may also have other rights that vary from state to state.



©Clipay Building Products Company, Inc.
A Griffon Company, Inc. 2003



America's Favorite Garage Doors™